

---

## ELECTRO-MECH SCOREBOARD CO.

|   |  |  |
|---|--|--|
| <p><b>GUEST</b></p> <p><b>BONUS</b></p> |  | <p><b>HOME</b></p> <p><b>BONUS</b></p> |
|   | <p>1 2      <b>TIME</b>      3 4</p> <p>○ ○      ○ ○      ○ ○</p> <p>◀ <b>POSS</b> ▶</p> |  |
| <p><b>FOUL</b></p>                      | <p><b>PLAYER</b></p>   | <p><b>FOUL</b></p>                     |

**MP-259/220, MP-259/220V, MP-259/220W, MP-269/220,  
MP-269/220V, MP-269/220W BASKETBALL SCOREBOARDS**

### OWNER'S HANDBOOK

Thank you for choosing an Electro-Mech Scoreboard for your athletic complex. We are confident that your new scoreboard will give many years of reliable service.

---

## TABLE OF CONTENTS

|   |           |
|---|-----------|
| <b>BASKETBALL SCOREBOARD SPECIFICATIONS .....</b>                     | <b>3</b>  |
| <b>MODELS .....</b>   | <b>4</b>  |
| <b>SCOREBOARD INSTALLATION.....</b>                                   | <b>4</b>  |
| MOUNTING THE SCOREBOARD .....   | 4         |
| ELECTRICAL CONNECTIONS .....  | 6         |
| <b>Connecting The Scoreboard To Your Power Source .....</b>           | <b>6</b>  |
| <b>Installing The Control Cable .....</b>                             | <b>8</b>  |
| <b>Connecting The Control Console .....</b>                           | <b>9</b>  |
| <b>Installation of Two or More Scoreboards at the Same Site .....</b> | <b>9</b>  |
| <b>SCOREBOARD OPERATION .....</b>                                     | <b>10</b> |
| <b>SERVICING THE SCOREBOARD .....</b>                                 | <b>15</b> |
| PLUG IN MODULE REPLACEMENT .....                                      | 16        |
| LAMP REPLACEMENT .....  | 17        |
| <b>WARRANTY.....</b>  | <b>18</b> |

## BASKETBALL SCOREBOARD SPECIFICATIONS

**GENERAL:** These scoreboards display HOME and GUEST scores to 199, a 99:00 clock with 1/10<sup>th</sup> of a second timing, quarters, HOME and GUEST bonus and possession indicators, HOME and GUEST team fouls, PLAYER NUMBER and FOULS, and a horn. This ETL listed scoreboard is remotely operated from one control console via a dedicated control cable.

**DIMENSIONS:** MP-259/220: 8' L x 5' H x 6" D, MP-269/220: 12' L x 5' H x 6" D

**WEIGHT:** MP-259/220: 220 lbs, MP-269/220: 275 lbs

**SCOREBOARD CONSTRUCTION:** The scoreboard is constructed of aluminum. MP-269/220 includes a 4' x 5' sponsor panel. The standard color is black.

**LAMP BANKS:** A 4 x 7 matrix of lamps forms each 14" digit. Two lamps form the BONUS indicators, two lamps form the possession indicators, and four lamps form the quarter indicators. The scoreboard uses 7.5 watt 125 VAC painted medium based appliance lamps (also known as S11 lamps). Recessed aluminum reflectors provide a crisp separation between each lamp.

**POWER REQUIREMENTS:** **Scoreboard** - 120 VAC, 18.625 A, 60 Hz, 2235 watts maximum, (25 A service recommended). **Control Console** - 120 VAC, 0.5 A, 60 Hz

**SCOREBOARD ELECTRONICS:** 100% solid state fully enclosed within three plug in modules.

**CONTROL CONSOLE:** The microprocessor control console is constructed of a rugged plastic housing with a metal back plate. It features a lithium cell battery backup to retain game information, a 37 key sealed membrane keypad, and a LCD display of game information.

**CONTROL CABLE:** The cable has two 22 AWG stranded copper conductors with semi-rigid PVC insulation. It also has a braided shield and a foil shield. The polyethylene jacket is rated at 300 volts. One length is required to run from the scoreboard to the point of operation.

**JUNCTION BOX:** A 4 1/4" x 2 1/4" x 2" junction box with a stereo jack mounted on the face plate is provided.

**WARRANTY:** Five year limited warranty.

## MODELS

This manual covers models MP-259/220, MP-259/220V, MP-259/220W, MP-269/220, MP-269/220V, MP-269/220W scoreboards. The MP-269/220, MP-269/220V, and MP-269/220W models have a 4 foot x 5 foot side sponsor panel. The V designation indicates volleyball captions and the W designation indicates wrestling captions. All the models covered in this manual are electrically identical. Except for the scoreboard size, weight, and spacing between the hanger brackets, references to MP-259/220 are intended to cover all models.

## SCOREBOARD INSTALLATION

This scoreboard is designed for indoor use only. Installation of the scoreboard consists of mounting the scoreboard cabinet to the wall and making the proper electrical connections.

## MOUNTING THE SCOREBOARD

There are two eyebolts mounted at the top of the cabinet which can be used to lift the scoreboard into place. Once the scoreboard is in the desired location, it can be fastened to the wall using lag bolts or other suitable hardware. Hanger brackets at the top of the scoreboard provide convenient mounting points. Figure 1 shows the mounting point locations for MP-259/220.

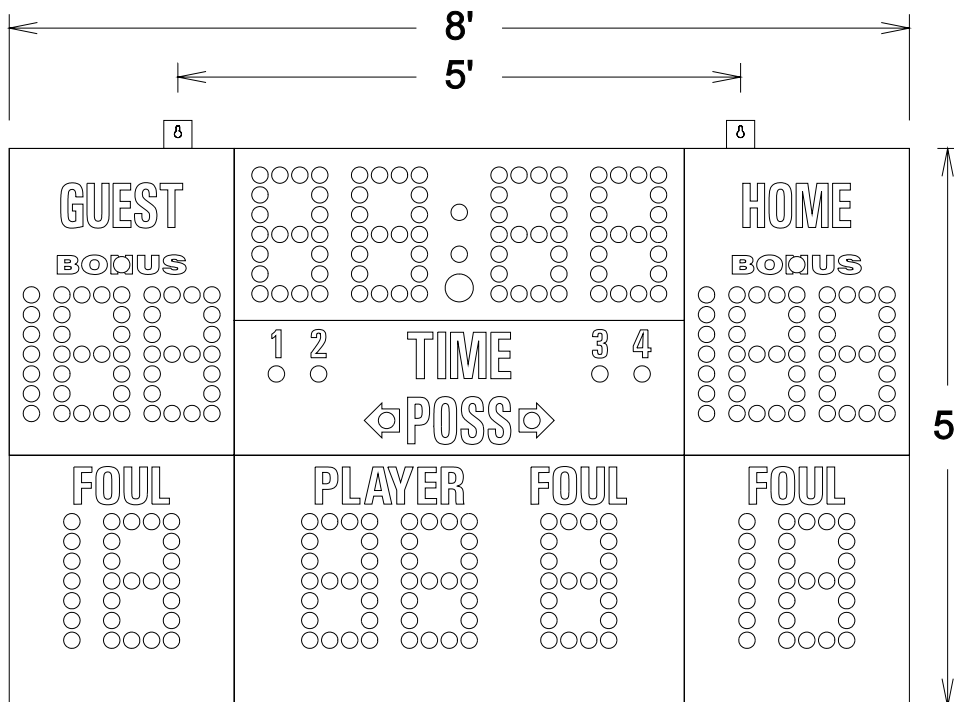

**Figure 1 MP-259/220 Mounting Points**

Figure 2 shows the mounting point locations for MP-269/220.

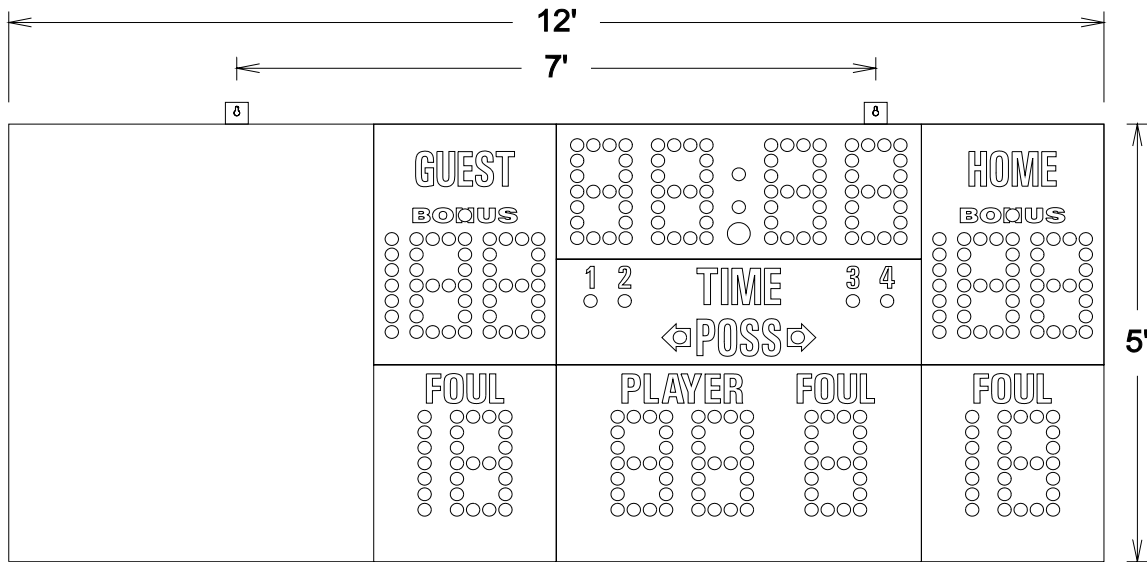

**Figure 2 MP-269/220 Mounting Points**

## ELECTRICAL CONNECTIONS

This scoreboard was designed to make the electrical connections as easy as possible. These connections include connecting the scoreboard to a power source, installing the control cable, and connecting the control console. Figure 3 shows the electrical connection points on the scoreboard. The power connection is made to a terminal strip inside the box mounted on the top of the cabinet. The stereo jack is mounted on the fuse plate. We recommend a qualified electrician perform the needed electrical connections to ensure proper operation of your scoreboard.

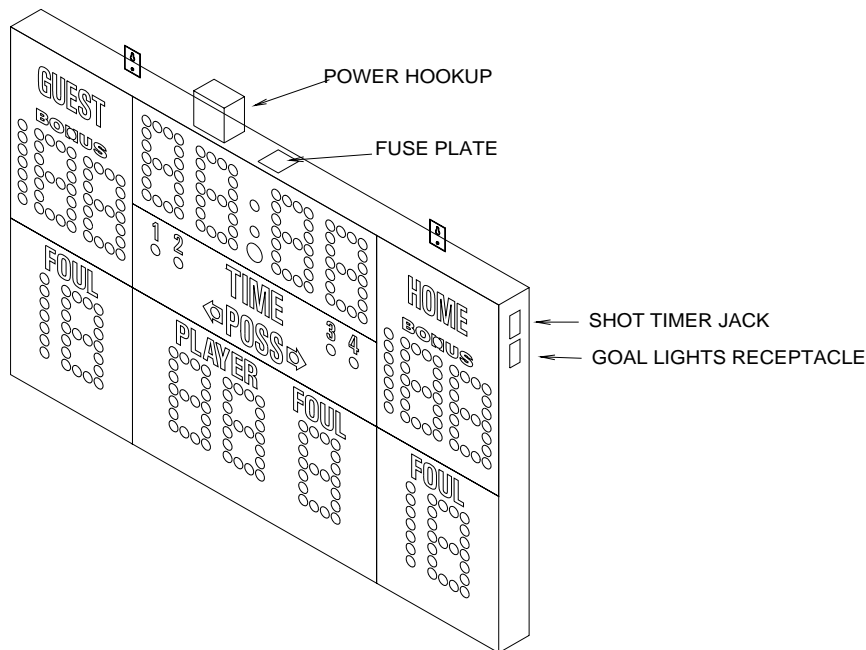

**Figure 3 Electrical Connection Points**

### Connecting The Scoreboard To Your Power Source

The scoreboard may be connected to 240 VAC single phase or 120 VAC service at the scoreboard. **Maximum power consumption of Model MP-259/220: 2235 Watts.** Make sure that the power cables are rated for this electrical load. If you are going to connect the scoreboard to a 240 VAC supply, connect one AC line wire to position 1, AC neutral wire to position 2, and the other AC line wire to position 3 of terminal strip inside the box mounted on the top of the scoreboard according to figure 4.

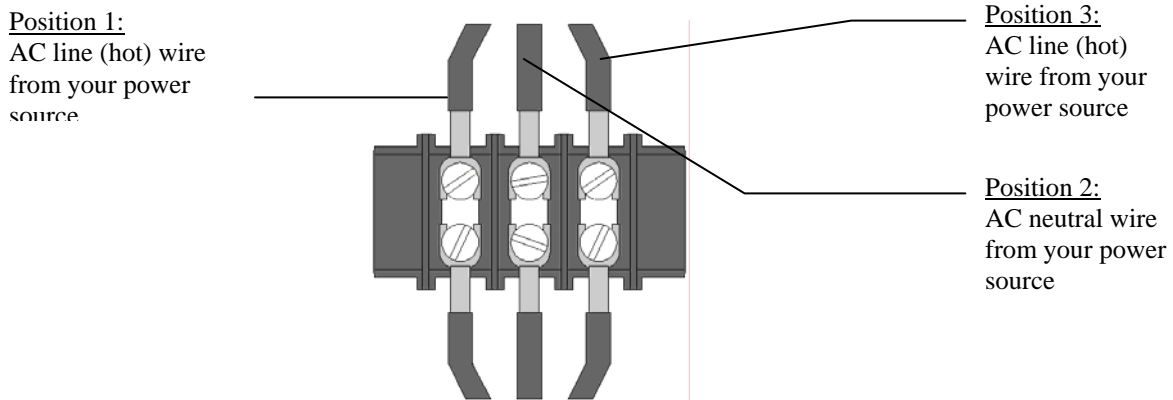
**Figure 4 240 VAC Connections**

If you are going to connect the scoreboard to a 120 VAC supply, connect the AC line wire to position 1 and the AC neutral wire to position 2 of terminal strip. Add a jumper from position 1 to position 3. **This jumper is not provided.** Refer to figure 5.

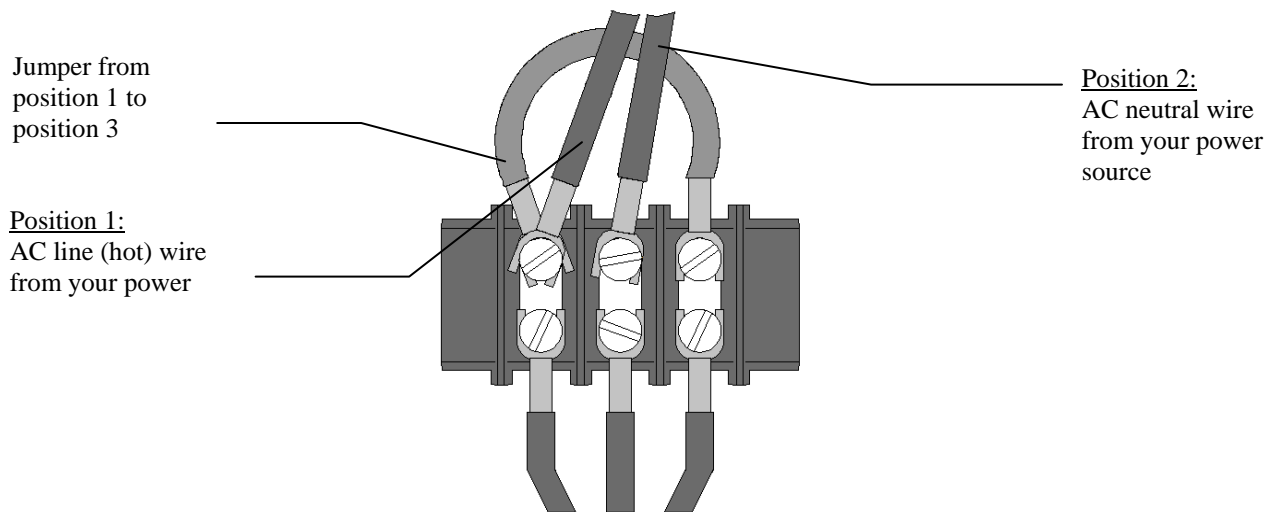
**Figure 5 120 VAC Connections**

### Installing The Control Cable

The control cable connects the scoreboard to the control console. A small junction box with a stereo jack mounted on the face plate is attached to the control cable at the point of operation of the scoreboard. A stereo plug is attached to the scoreboard end of the control cable. The junction box should be securely mounted within ten feet of the rear of the control console. Most customers order the control cable with the junction box and stereo plug attached to the control cable. Some customers prefer to attach them after the cable is installed. Those customers must match their stereo jack to one of the stereo jacks in figure 6 in order to make the proper connections. These connections should be soldered.

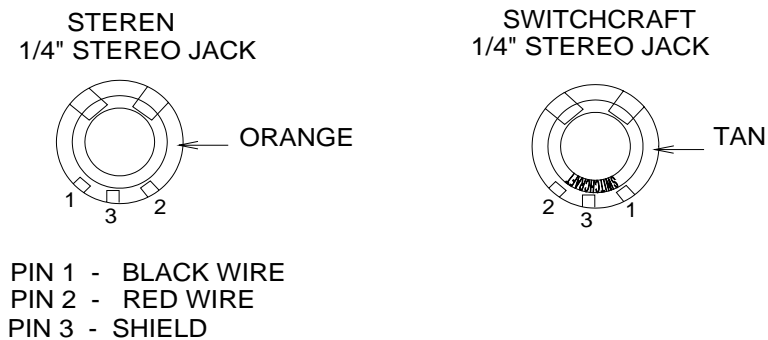

**Figure 6 Stereo Jack Wiring Diagram**

Attach a stereo plug to the scoreboard end of the cable according to the figure 7. Insert the stereo plug into the stereo jack mounted on top of the scoreboard.

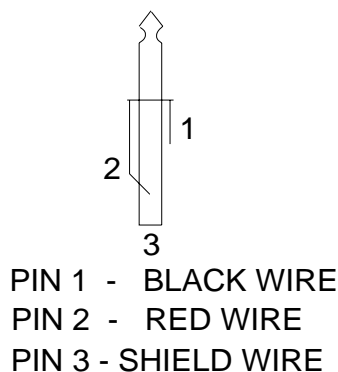

**Figure 7 Stereo Plug Wiring Diagram**



### **Connecting The Control Console**

The control console is connected to the junction box via the extension cable. This extra length of cable allows the scoreboard operator some mobility and the ability to store the control console after the game. The control console requires a 120 VAC 1/2 A power source. The power cord can be plugged into a NEMA 5-15R receptacle.

This product is equipped with a 3-wire grounding type plug, a plug having a third (grounding) pin. This plug will only fit into a grounding-type power outlet. This is a safety feature. If you are unable to insert the plug into the outlet, contact a qualified electrician to replace your obsolete outlet. Do not defeat the purpose of the grounding-type plug.

**Step 1:** Connect one end of the extension cable to the jack on the junction box.

**Step 2:** Connect the other end of the extension cable to the jack on the rear of the control console.

**Step 3:** Plug the control console power cord into a 120 VAC outlet.

### **Installation of Two or More Scoreboards at the Same Site**

It is possible to operate up to four scoreboards from the same console. Install a control cable line in the same manner as described previously for each additional scoreboard. Connect the additional control cable lines with extension cables to the control console. **Never operate two scoreboards from the same control cable.**

## SCOREBOARD OPERATION

The MP-259/220 Scoreboard is operated by the control console. **No scoreboard functions will operate without connecting the control console.** Figure 8 shows the keypad layout on your control console. The various keypad functions are described in the text below the figure.

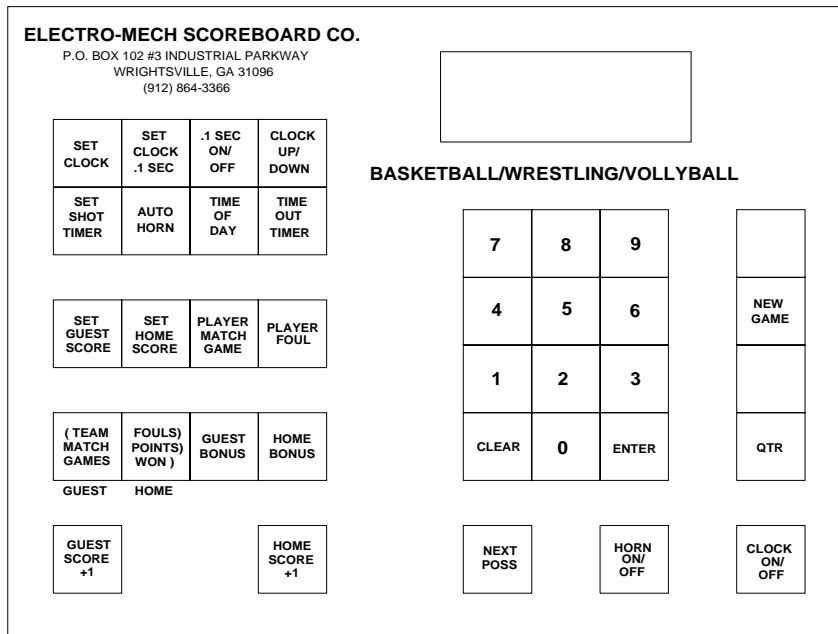

**Figure 8 Keypad Layout**

### Control Console Key Functions

1. **SET CLOCK** – This key sets the time displayed on the scoreboard clock. Press [SET CLOCK], the keypad numbers for the time, [ENTER]. Example: Press [SET CLOCK], [6], [0], [0], [0], [ENTER] on the control console. 60:00 will be displayed on the clock section of the scoreboard.
2. **SET CLOCK .1 SEC** – This key is used when the clock is in the 1/10<sup>th</sup> second mode. Press [SET CLOCK .1 SEC], the keypad numbers for the time, [ENTER]. Example: Press [SET CLOCK .1 SEC], [5], [3], [8], [ENTER] on the control console. 53.8 will be displayed on the clock section of the scoreboard.

- .1 SEC ON OFF** – This key is used to enable or disable the 1/10<sup>th</sup> second mode on the scoreboard. This mode is enabled when the control console is turned on. If it is disabled, the LCD display on the control console will still show 1/10<sup>th</sup> second timing, but the scoreboard will not display it. To turn this function off, press [.1 SEC ON/OFF]. The console LCD display will read:

|                |
|----------------|
| CLOCK ON - 1   |
| .1 SEC OFF - 0 |

Press [0], [ENTER] on the control console.

- CLOCK UP / DOWN** – The clock can be set up to either count up or count down. The control console will reset to the clock down mode when it is turned on. To make the clock count up, press [CLOCK UP / DOWN]. The console LCD display will read:

|                |
|----------------|
| GAME UP - 1    |
| CLOCK DOWN - 0 |

Press [0], [ENTER] on the control console. To reset the clock to count down mode, press [CLOCK UP / DOWN], [1], [ENTER] on the control console.

- SET SHOT TIMER** – The shot timer default time is 30 seconds. To change this time, press [SET SHOT TIME]. The console LCD display will read:

|               |
|---------------|
| ST RESET <30> |
|---------------|

Press the keypad numbers for the time, [ENTER]. The LCD display will then read:

|                  |
|------------------|
| ST-OB RESET <05> |
|------------------|

This will allow you to change the out of bounds time. To change this time, press the keypad numbers for the time, [ENTER].

6. **AUTO HORN** – This key allows the operator to control the end of period horn and / or the time out horn. The horn normally sounds for two seconds when the clock reaches 0:00. The end of period horn can be disabled by pressing [AUTO HORN]. The console LCD display

|                    |
|--------------------|
| GAME PRESS <1> ON  |
| HORN PRESS <0> OFF |

will read:

Press [0], [ENTER] to disable the horn. The console LCD display will then read:

|                    |
|--------------------|
| T-O PRESS <1> ON   |
| HORN PRESS <0> OFF |

The time out horn is normally disabled. To enable the horn to sound at the end of the time out, press [1], [ENTER] on the control console.

7. **TIME OF DAY** – The time of day can be displayed on the clock section of the scoreboard. **THE GAME CLOCK WILL BE INOPERABLE UNTIL THE TIME OF DAY FUNCTION IS TURNED OFF.** To turn the time of day clock on, press [TIME OF DAY]. The console LCD display will read:

|           |         |
|-----------|---------|
| TIME OF   | ON <1>  |
| DAY CLOCK | OFF <0> |

Press [1], [ENTER] on the control console. The console LCD display will then read:

|                 |
|-----------------|
| SET CLK <__:__> |
|-----------------|

Press the keypad numbers for the time, [ENTER]. The scoreboard will display the time of day.

8. **TIME OUT TIMER** – To set the Time Out timer, press [TIME OUT TIMER]. The console LCD display will read:

SET T-O <\_:\_\_>

Press the keypad numbers for the time, [ENTER]. The scoreboard will not display the Time Out time.

9. **SET GUEST SCORE** – To set the guest score, press [SET GUEST SCORE], the keypad numbers for the time, [ENTER]. **EXAMPLE:** To set the guest score to 53, press [SET GUEST SCORE], [5], [3], [ENTER].
10. **SET HOME SCORE** – To set the home score, press [SET HOME SCORE], the keypad numbers for the time, [ENTER]. **EXAMPLE:** To set the home score to 75, press [SET HOME SCORE], [7], [5], [ENTER].
11. **PLAYER MATCH GAME** – This key is used to display the number of the player who committed a foul. To display the player number, press [PLAYER MATCH GAME], the keypad numbers for the player number, [ENTER]. **EXAMPLE:** Player 12 commits a foul. Press [PLAYER MATCH GAME], [1], [2], [ENTER]. 12 will be displayed in the player section of the scoreboard.
12. **PLAYER FOUL** – This key allows the scorekeeper to display the number of fouls that the player has committed. To display the number of fouls, press [PLAYER FOUL], the keypad number for the number of fouls, [ENTER]. **EXAMPLE:** Player 12 has committed his second foul. Press [PLAYER FOUL], [2], [ENTER]. 2 is displayed on the player foul digit.
13. **GUEST TEAM FOULS, MATCH POINTS, GAMES WON** – This key increments the number of fouls that the guest team had committed.
14. **HOME TEAM FOULS, MATCH POINTS, GAMES WON** – This key increments the number of fouls that the home team had committed.
15. **GUEST BONUS** – This key toggles the guest bonus indicator on and off.
16. **HOME BONUS** – This key toggles the home bonus indicator on and off.
17. **GUEST SCORE +1** – This key increments the guest score by one point.

18. **HOME SCORE +1** – This key increments the home score by one point.
19. **NEXT POSS** – This key toggles the possession indicators between guest and home.
20. **HORN ON/OFF** – This key is used to sound the horn for ½ second.
21. **CLOCK ON/OFF** – This key is used to start and stop the clock.
22. **NEW GAME** – This key is used to reset all the scoreboard functions to their default settings. To reset the scoreboard, press [NEW GAME]. The console LCD display will read:

|            |         |
|------------|---------|
| RESET      | YES <1> |
| SCOREBOARD | NO <0>  |

Press [1], [ENTER] on the control console. The scoreboard will reset its functions.

23. **QTR** – This key increments the quarter indicators.
24. **CLEAR** – This key clears the information being entered into the control console.

After applying power to the control console you should reset the scoreboard using **NEW GAME** key as described above. Test out all the other keys to ensure that the scoreboard is operating properly. It is a good idea to store the control console and the extension cable in a safe place when the scoreboard is not in use.

## SERVICING THE SCOREBOARD

While your scoreboard was designed for years of trouble-free operation, some problems may occasionally occur. Our trained personnel at Electro-Mech Scoreboard Company are ready to answer your questions from Monday to Friday during the hours of 8 AM to 5 PM Eastern Standard Time. Be sure to know your scoreboard model number when calling. Scoreboard replacement parts, including lamps, are always available. Electro-Mech Scoreboard Company can repair the control console and plug in module at a significant savings when compared to the price of new units. Our convenient toll free number is listed at the bottom of every page in this manual.

As seen in figure 9, the plug in modules MSB-01, MC-01, and MBB-01 are located behind the QUARTER panel.

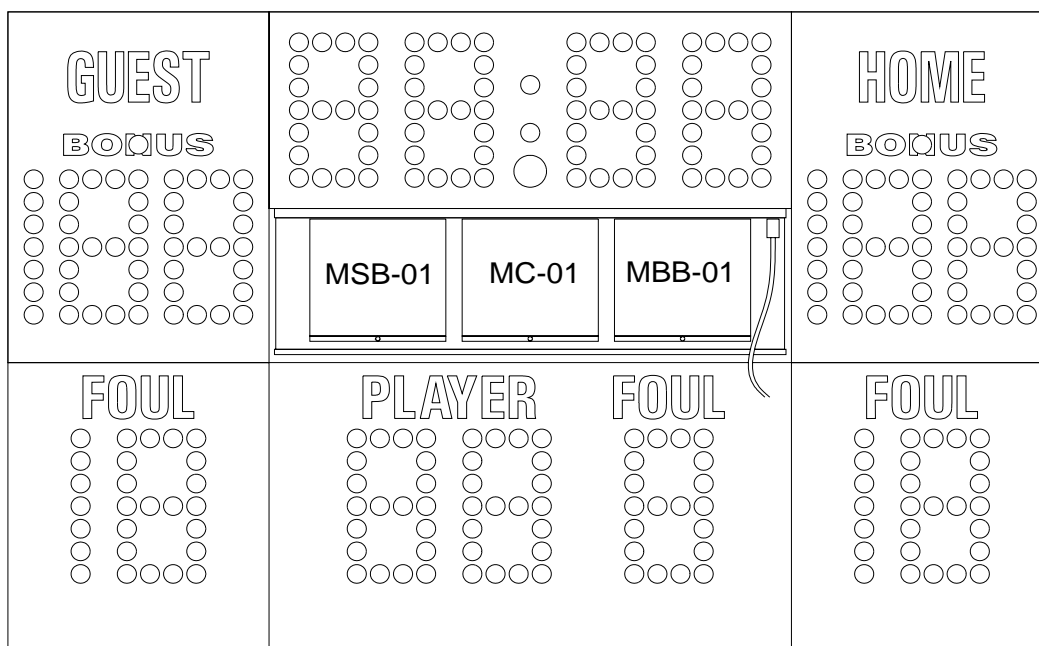

**Figure 9 SCOREBOARD ELECTRONICS**

The plug in module MSB-01 operates GUEST SCORE, HOME SCORE, and the BONUS and POSSESSION indicators. The plug in module MC-01 operates the CLOCK and the QUARTER indicators. The plug in module MBB-01 operates the team fouls, player fouls, and player number. The fuses are mounted on a plate on the top of the scoreboard cabinet as shown in figure 10.

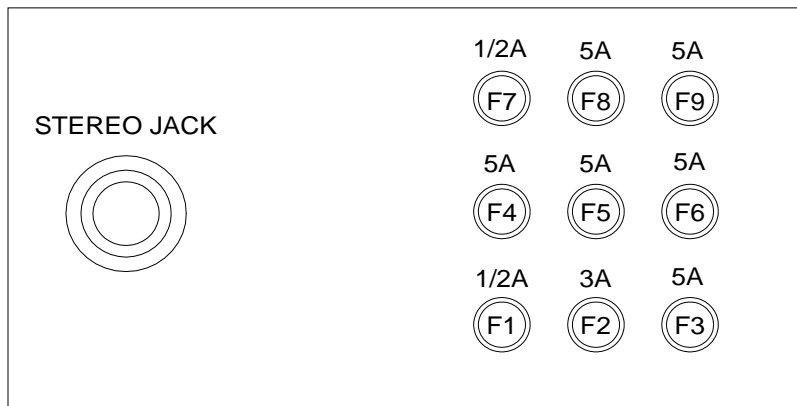
**Figure 10 Fuses**

The table below lists the fuses, the fuse ratings, and their functions.

| FUSE | RATING      | FUNCTION                                      |
|------|-------------|---|
| F1   | 1/2 A 250 V | CONTROL LINE                                  |
| F2   | 3 A 250 V   | HORN, QUARTER, POSSESSION, COLON, GOAL LIGHTS |
| F3   | 5 A 250 V   | HOME SCORE, BONUS                             |
| F4   | 5 A 250 V   | GUEST SCORE, BONUS                            |
| F5   | 5 A 250 V   | SECONDS                                       |
| F6   | 5 A 250 V   | MINUTES                                       |
| F7   | 1/2 A 250 V | CONTROL LINE                                  |
| F8   | 5 A 250 V   | GUEST FOULS, HOME FOULS                       |
| F9   | 5 A 250 V   | PLAYER NUMBER, PLAYER FOULS                   |

## PLUG IN MODULE REPLACEMENT

The plug in modules can be accessed by removing the QUARTER panel. Remove the hex head screws which hold the panel in place. Unplug the cable which is attached to the rear side of the QUARTER panel. Each module has four top plugs which mate with sockets in the scoreboard. A screw located at the bottom of the module holds it against the scoreboard cabinet. Simply remove the screw and pull the module downward to unseat the module. **To avoid damage to the plug in module, always turn off the power to the scoreboard when removing or replacing it.**



## LAMP REPLACEMENT

Replacing lamps may be the only service you ever perform on your Electro-Mech scoreboard. A rubber tool is provided with the scoreboard to aid the removal and replacement of lamps. **To avoid damage to the plug in module, always turn off the power to the scoreboard when changing lamps.** We recommend using a felt pen or tape to mark lamps that will not light. This scoreboard uses 7.5 watt medium base lamps (also called S11 lamps). **Never replace these with higher wattage lamps.**

## ELECTRO-MECH SCOREBOARD CO. FIVE YEAR LIMITED WARRANTY

THE ELECTRICAL COMPONENTS OF ALL ELECTRO-MECH SCOREBOARDS ARE GUARANTEED FOR A PERIOD OF FIVE (5) YEARS FROM THE DATE OF INVOICE AGAINST DEFECTS IN WORKMANSHIP OR MATERIAL AND WILL BE REPLACED OR REPAIRED WITHOUT COST TO THE OWNER PROVIDED THE EQUIPMENT OR PARTS ARE RETURNED POSTAGE-PAID TO THE FACTORY IN WRIGHTSVILLE, GA. SHIPPING BACK TO THE OWNER WILL BE VIA UPS GROUND SERVICE EXCEPT WHEN AIR OR SPECIAL METHOD OF RETURN IS SPECIFIED BY THE OWNER, IN WHICH CASE SHIPPING WILL BE FREIGHT COLLECT.

EXCLUDED FROM THIS WARRANTY ARE LAMPS, FUSES AND SOCKETS.

THIS WARRANTY DOES NOT INCLUDE LABOR CHARGES INCURRED IN THE REMOVAL OF COMPONENT PARTS, SERVICE CALLS, OR DAMAGES RESULTING FROM IMPROPER INSTALLATION, IMPROPER OPERATION, OR PROBLEMS CAUSED BY ANY REPAIR, ALTERATION OR MODIFICATION OF THE SCOREBOARD NOT PERFORMED BY ELECTRO-MECH.

EQUIPMENT WHICH IS SUBJECTED TO ACCIDENT, NEGLIGENCE, ABUSE, MISUSE OR OTHER NATURAL DISASTERS, INCLUDING BUT NOT LIMITED TO FIRE, WIND, LIGHTNING, OR FLOOD, IS NOT COVERED BY THIS GUARANTEE.