ELECTRO-MECH SCOREBOARD CO.

<i>BATTER</i>	<i>BALL</i>	<i>STRIKE</i>	<i>OUT</i>										
1	2	3	4	5	6	7	8	9	10	<i>RUNS</i>	<i>HITS</i>	<i>ERRORS</i>	
<i>GUEST</i>													
<i>HOME</i>													

MP-158 BASEBALL SCOREBOARD

OWNER'S HANDBOOK

Thank you for choosing an Electro-Mech Scoreboard for your athletic complex. We are confident that your new scoreboard will give many years of reliable service.

TABLE OF CONTENTS

MP-158 BASEBALL SCOREBOARD SPECIFICATIONS	3
SCOREBOARD INSTALLATION.....	4
POSITIONING THE POSTS.....	4
MOUNTING HARDWARE.....	6
MOUNTING THE OPTIONAL TOP SPONSOR PANEL	6
MOUNTING THE SCOREBOARD	7
ELECTRICAL CONNECTIONS	8
Ground Connection	8
Top Access Panel Power Connection	8
Bottom Access Panel Power Connection.....	9
Top Access Panel Control Cable Connection.....	9
Bottom Access Panel Control Cable Connection	10
Connecting The Scoreboard To Your Power Source	10
ScoreLink 300.....	12
Installing The Control Cable	12
Connecting The Control Console	13
SCOREBOARD OPERATION	14
SERVICING THE SCOREBOARD.....	18
PLUG IN MODULE REPLACEMENT	22
LAMP REPLACEMENT	22
WARRANTY.....	23

MP-158 BASEBALL SCOREBOARD SPECIFICATIONS

GENERAL: This ETL listed scoreboard includes the scoreboard cabinet, mounting hardware, control console, control cable (sold separately), 10 ft. extension cable, and junction box.

DIMENSIONS: 36' L x 10' H x 6" D (top section: 36' L x 54" H x 6" D, middle section: 36' L x 40.75" H x 6" D, bottom section: 36' L x 25.25" H x 6" D) Optional top sponsor panel: 36' L x 33" H x 6" D

WEIGHT: 1275 lbs (top section: 400 lbs, middle section: 515 lbs, bottom section: 360 lbs) optional sponsor panel: 230 lbs

SCOREBOARD CONSTRUCTION: The scoreboard consists of three aluminum sections. The outer frame is made from extruded aluminum. Internal structural parts may be extruded or formed from aluminum sheet. The face and back are made from aluminum sheet. The face is finished with enamel paint. Black is the standard face color. White is the standard color for the captions. Mounting hardware is included.

DISPLAY: The MP-158 baseball scoreboard displays inning by inning scores from 0 to 9 for VISITOR and HOME, total RUNS and HITS to 99, total ERRORS to 9, BATTER NUMBER to 99, BALLS, STRIKES, OUTS, HIT and ERROR.

LAMP BANKS: A 4 x 7 matrix of lamps forms each digit. The BATTER NUMBER, BALLS, STRIKES, and OUTS are 24" tall. All other digits are 18" tall. The scoreboard uses 15 watt 120 VAC frosted medium based appliance lamps (also known as 15A15IF lamps). Recessed aluminum reflectors provide a crisp separation between each lamp. Expanded metal screens protect the lamps.

POWER REQUIREMENTS: Scoreboard - 120 VAC, 91.5 A, 60 Hz, 10980 watts maximum, (120 A service recommended). The scoreboard may be connected to either 120 VAC or 240 VAC single phase. **Control Console** - 120 VAC, 0.5 A, 60 Hz

SCOREBOARD ELECTRONICS: 100% solid state fully enclosed within 7 plug in modules.

CONTROL CONSOLE: The microprocessor control console is constructed of a rugged plastic housing with a metal back plate. It features a 37 key sealed membrane keypad, a LCD display of game information, an attached 6 foot power cord, and a lithium cell battery backup to retain game information.

CONTROL CABLE: The cable has two 22 AWG stranded copper conductors with semi-rigid PVC insulation. It also has a braided shield and a foil shield. The polyethylene jacket is rated at 300 volts. The cable is direct burial rated and measures approximately 1/4" in diameter. One length is required to run from the scoreboard to the point of operation (conduit installation recommended).

JUNCTION BOX AND EXTENSION CABLE: A 4 1/4" x 2 1/4" x 2" junction box with a stereo jack mounted on the face is attached to the control cable at the point of operation. A ten foot extension cable connects the control console to the junction box.

WARRANTY: Five year limited warranty.

SCOREBOARD INSTALLATION

Installation of the MP-158 Scoreboard consists of positioning the posts, mounting the scoreboard on the posts, and making the proper electrical connections.

Items not provided by Electro-Mech Scoreboard Company which are necessary for installation:

- Four posts
- Power cable to connect the scoreboard to your power source
- Grounding hardware
- A grounded NEMA 5-15R 120 VAC receptacle for the control console.

Items not provided which are recommended by Electro-Mech Scoreboard Company for installation:

- A weatherproof power disconnect at the scoreboard
- A weatherproof NEMA 5-15R 120 VAC convenience receptacle at the scoreboard

While Electro-Mech Scoreboard Company does not perform installations, we will make every effort to answer your installation questions. Installation should be performed by qualified personnel. Consult national and local codes before installation.

POSITIONING THE POSTS

The scoreboard is designed to be mounted on four posts. We suggest that the front of the scoreboard should be angled away from the afternoon sun, if possible. Typically installers will use steel pipes or I-beams. The mounting hardware will accommodate posts up to 7 inches outer diameter. We recommend that the posts are sunk in reinforced concrete footings. Figure 1 shows the spacing of the posts for a MP-158. It suggests one possible installation for a MP-158 in silty sand soil. **No dimensional data in this manual is intended to be specifications except the size of the scoreboard cabinet and the distance between the posts.** The specifications for the posts and concrete footings are dependent upon the expected local wind and soil conditions, the height of the scoreboard from the ground, and the local building codes. Electro-Mech Scoreboard Company assumes no responsibility for the installation of scoreboards by others.

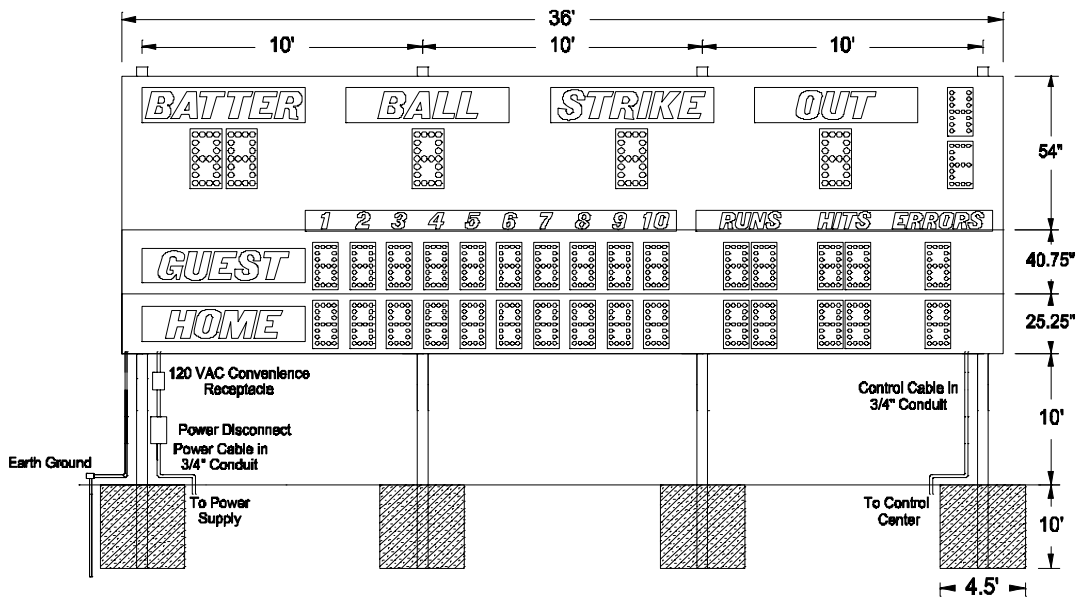

Figure 1 MP-158 Post Spacing

Figure 2 shows the spacing of the posts for a MP-158 with an optional top sponsor panel.

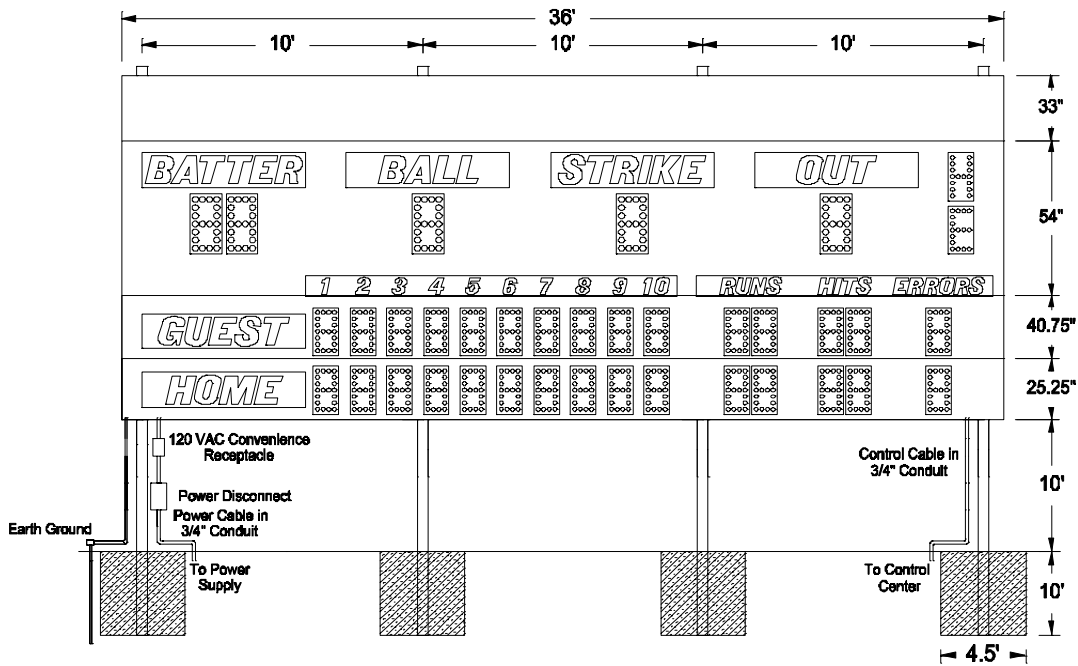

Figure 2 MP-158 with Optional Top Sponsor Panel Post Spacing

MOUNTING HARDWARE

Twenty four sets of mounting hardware are provided to attach the scoreboard to the posts. Additional hardware sets are provided to attach the optional sponsor panels, if ordered. A mounting hardware set consists of a steel angle bracket, two threaded rods, two washers, and two nuts. Figure 3 shows an overhead cross section view and a side cross section view of the scoreboard attached to a post at a mounting point using the hardware. A steel bracket is riveted to the scoreboard's aluminum extrusion frame. The bracket has two tapped holes. The threaded rods screw into these tapped holes. The washers and nuts are used to clamp the steel angle bracket against the steel post and hold the scoreboard in place.

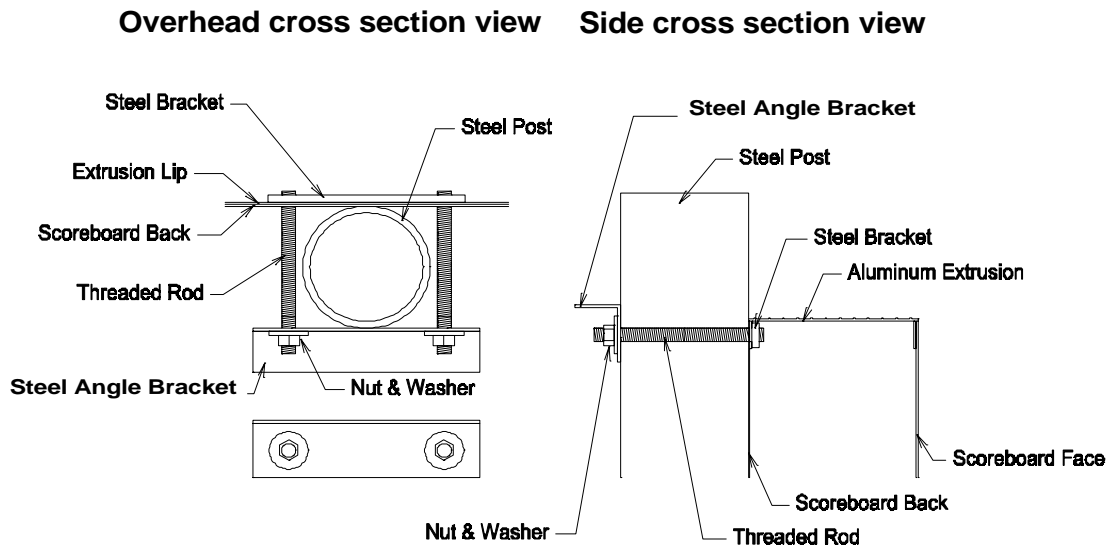

Figure 3 Standard Mounting Method

MOUNTING THE OPTIONAL TOP SPONSOR PANEL

The following steps describe how to mount the top sponsor panel on the posts:

1. Place the top sponsor panel against the posts on the ground. Make sure the mounting points are aligned with the posts.
2. Screw the threaded rods into the tapped holes in the top sponsor panel.
3. Place a steel angle bracket over the threaded rods at a mounting point.
4. Place a washer over each threaded rod.
5. Screw the nuts onto the threaded rods so that the bracket is **loosely** held in place.
6. Repeat steps 4 -6 at the other mounting points.
7. Raise the top sponsor panel into place and tighten the nuts to clamp it in place on the posts.

MOUNTING THE SCOREBOARD

Each section of the scoreboard is attached to the posts at eight points. Figure 4 shows the location of the mounting points on the rear of the scoreboard.

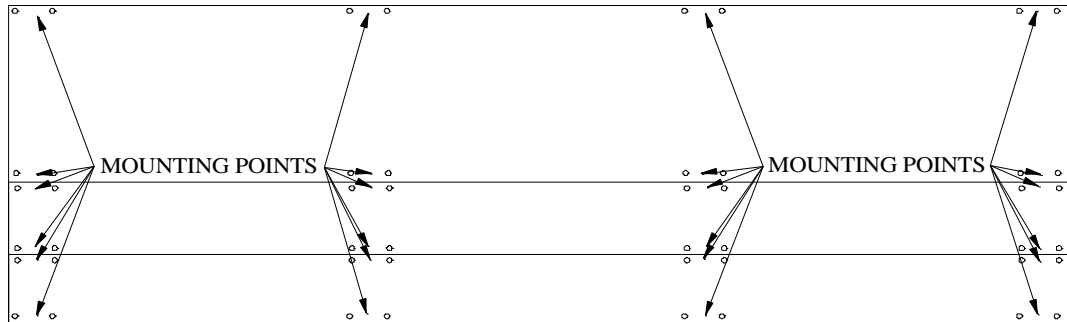

Figure 4 Mounting Points

The following steps describe how to mount the scoreboard on the posts:

1. Place the upper section of the scoreboard against the posts on the ground. Make sure the mounting points are aligned with the posts.
2. Screw the threaded rods into the tapped holes in the scoreboard.
3. Place a steel angle bracket over the threaded rods at a mounting point.
4. Place a washer over each threaded rod.
5. Screw the nuts onto the threaded rods so that the bracket is **loosely** held in place.
6. Repeat steps 4 -6 at the other mounting points.
7. Raise the section into place and tighten the nuts to clamp it in place on the posts.
8. Place the middle section of the scoreboard against the posts on the ground. Make sure the mounting points are aligned with the posts.
9. Attach the mounting hardware by the same method as the upper section.
10. Raise the middle section to the bottom of the upper section and tighten the nuts to clamp it in place on the posts.
11. Place the lower section of the scoreboard against the posts on the ground. Make sure the mounting points are aligned with the posts.
12. Attach the mounting hardware by the same method as the middle section.
13. Raise the lower section to the bottom of the middle section and tighten the nuts to clamp it in place on the posts.

ELECTRICAL CONNECTIONS

We recommend a qualified electrician perform the needed electrical connections to ensure proper operation of your scoreboard. These connections include grounding the scoreboard, connecting the scoreboard to a power source, making power and control connections between the two sections, installing the control cable, and connecting the control console. **Note: This manual makes references to numbered positions of terminal strips inside the scoreboard. The terminal strip positions are not marked inside the scoreboard. All of the terminal strips in this scoreboard are sequentially numbered starting with position 1 on the left end.**

Ground Connection

The National Electrical Code **requires** a scoreboard (electric sign) to be grounded. Grounding the scoreboard helps the scoreboard electronics operate properly and helps minimize damage if it is struck by lightning. Metal posts do **not** provide an adequate ground path when they are placed in concrete. One method of grounding is to connect each section of the scoreboard to one or more grounding rods which are driven into the ground near the scoreboard via a large gauge copper wire. The self tapping sheet metal screws on the back of the scoreboard cabinet provide a convenient connection point.

Top Access Panel Power Connection

Remove the knockout panel below the top access panel (figure 5).

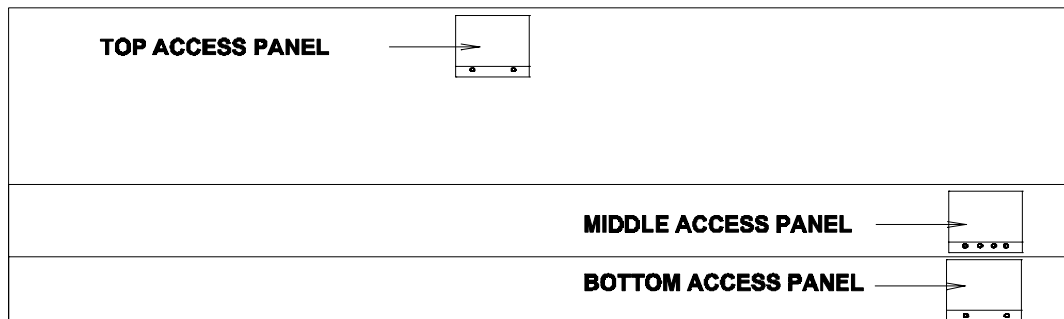

Figure 5 Rear Access Panels

The power cable that is attached to a terminal block (T2) that is labeled “power from middle section”. The control cable that is attached to a terminal block (T1) that is labeled “control from bottom section”. Punch out two knockouts and run the cables through the knockouts. Reattach the knockout panel. Punch out the knockouts below the middle access panel. Connect the power cable to T4 (labeled “power to top section”) on the junction chassis behind the middle access panel according to the table on the next page. Figure 6 shows the view behind the middle access panel. It is a good idea to run this cable in conduit.

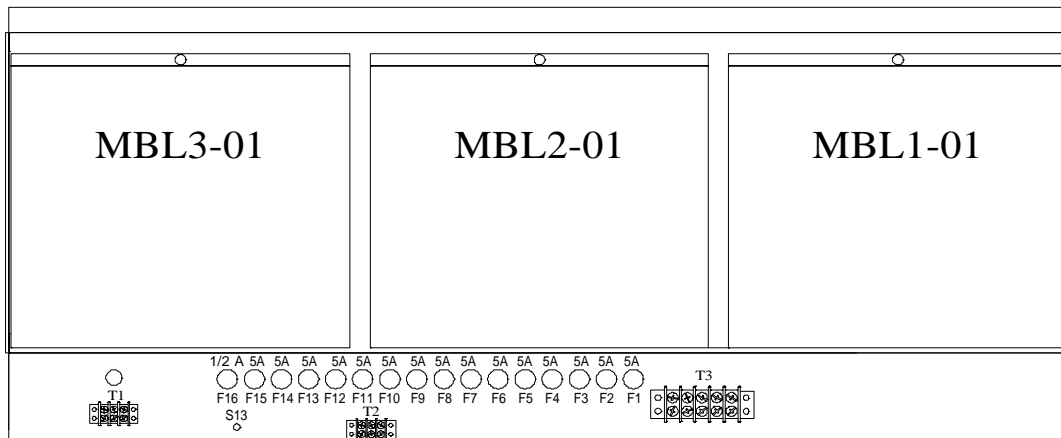

Figure 7 Bottom Access Panel Removed

Bottom Access Panel Control Cable Connection

Connect the bottom access panel control cable to T2 on the junction chassis behind the middle access panel (labeled “control to bottom section”) according to the table below. It is a good idea to run this cable in conduit.

WIRE	TO
black	middle access panel T2-1
red	middle access panel T2-2
shield	middle access panel T2-3

Connecting The Scoreboard To Your Power Source

The scoreboard may be connected to 240 VAC single phase or 120 VAC service at the scoreboard. **Maximum power consumption of Model MP-158: 10980 Watts.** Make sure that the power cables are rated for this electrical load. Electro-Mech Scoreboard Company recommends that your power cable is installed in conduit. **Avoid** running your power cables in close proximity to your control cable. The following steps describe how to connect the scoreboard to your power source:

1. Remove the hex head screws which hold the middle access panel on the rear of the scoreboard in place.
2. Punch out the knockouts for the power and control cables.
3. Feed the power cables through a knockout.
4. If you are going to connect the scoreboard to a 240 VAC supply, connect one AC line wire to position 2, AC neutral wire to position 3, and the other AC line wire to position 4 of terminal strip T5 on the junction chassis according to figure 8.

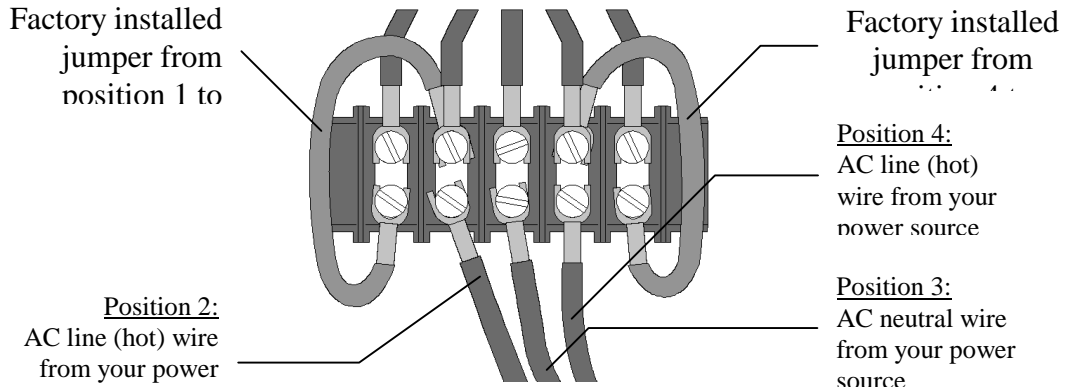

Figure 8 240 VAC Connections

5. If you are going to connect the scoreboard to a 120 VAC supply, connect the AC line wire to position 2 and the AC neutral wire to position 3 of terminal strip T3 on the junction chassis. Add a jumper from position 2 to position 4. **This jumper is not provided.** Refer to figure 9.

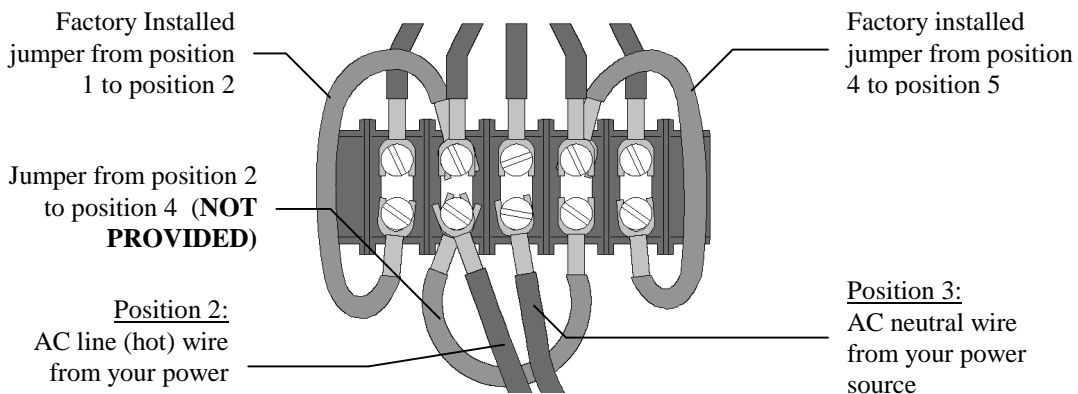

Figure 9 120 VAC Connections

Electro-Mech Scoreboard Company suggests that you install a power cut-off switch and a NEMA 5-15R receptacle in a weatherproof box on the scoreboard post below the scoreboard. The cut-off switch provides a convenient way of turning the scoreboard off during maintenance or repairs. The NEMA 5-15R receptacle will allow a technician to easily plug in the control console and operate the scoreboard via the test jack S13 behind the middle access panel (a valuable trouble-shooting aid).

ScoreLink 300

The SCORELINK 300 RF MODEM SET is intended to eliminate the control cable between the scoreboard and the control console on Electro-Mech Scoreboard MM and MP series scoreboards. If you have purchased this option, disregard the next section of this manual. Refer to the SCORELINK 300 RF MODEM SET OWNER'S HANDBOOK for installation instructions.

Installing The Control Cable

The control cable connects the scoreboard to the control console. While the control cable is direct burial rated, Electro-Mech Scoreboard Company recommends that it is installed in conduit to protect it from being cut. A small junction box with a stereo jack mounted on the face plate is attached to the control cable at the point of operation of the scoreboard. This junction box should be securely mounted in a clean, dry area within ten feet of the rear of the control console. Most customers order the control cable with the junction box attached. Some customers prefer to attach the junction box after the cable is installed. Those customers must match their stereo jack to one of the stereo jacks in figure 10 in order to make the proper connections. These connections should be soldered.

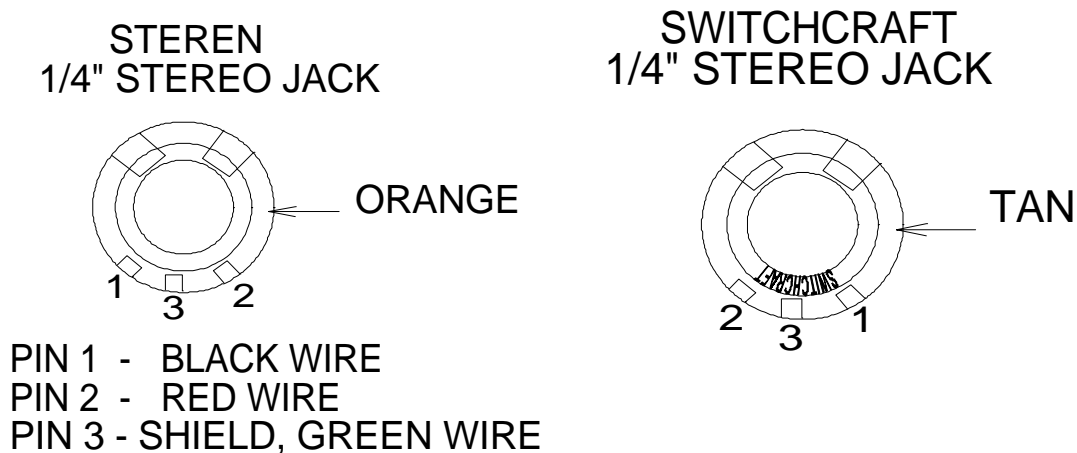

Figure 10 STEREO JACK WIRING DIAGRAM

The following steps describe how to connect the control cable to the scoreboard:

1. At the rear of the scoreboard feed the control cable through one of the knockouts below the middle access panel.
2. Crimp fork terminals to the control cable wires and the shield.
3. Connect the control cable to terminal strip T1 (located to the left of the test jack S13) according to the diagram in figure 11.

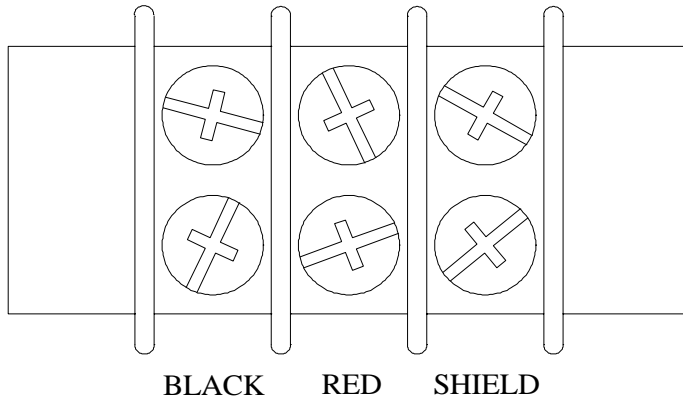

Figure 11 T1 WIRING DIAGRAM

Connecting The Control Console

The control console is normally connected to the junction box via the 10 ft. extension cable. This extra length of cable allows the scoreboard operator some mobility and the ability to store the control console after the game. The extension cable has two molded stereo plugs attached to it. One end of the extension cable is plugged into the junction box stereo jack and the other end is plugged into the stereo jack mounted on the control console back plate. The control console power cord is plugged into a grounded NEMA 5-15R 120 VAC receptacle.

SCOREBOARD OPERATION

The MP-158 Scoreboard is operated by the control console. **No scoreboard functions will operate without connecting the control console.** Figure 12 shows the keypad layout on your control console. The keypad functions are described in the text below the figure.

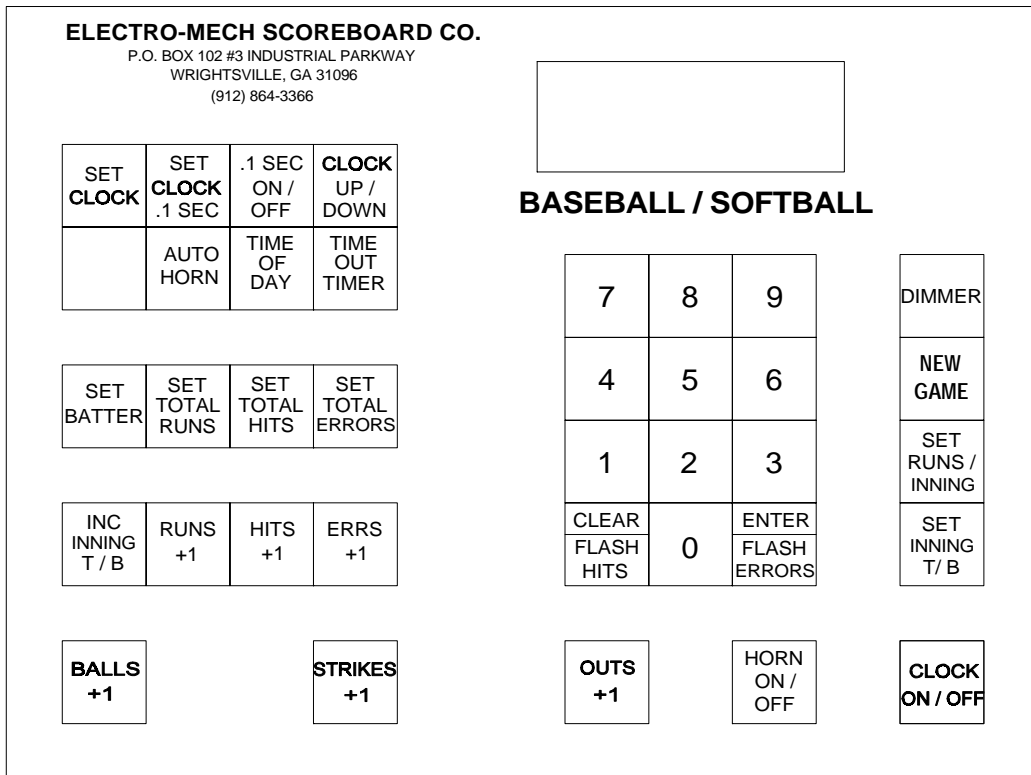

Figure 12 Keypad Layout

Control Console Key Functions

1. **SET BATTER** – Press [SET BATTER][2][5][ENTER] to display Batter number 25.

2. **SET TOTAL RUNS** – Press [SET TOTAL RUNS]. The LCD display will read:

00 D15:00 00 TOT RUNS TOP<00>

Press [3][ENTER] to set the Visitor runs to 3. The LCD display will then read:

03 D15:00 00 TOT RUNS BOT<00>

Press [2][ENTER] to set the Home runs to 2.

3. **SET TOTAL HITS** – Press [SET TOTAL HITS]. The LCD display will read:

03 D15:00 02 TOT HITS TOP<00>

Press [5][ENTER] to set the Visitor hits to 5. The LCD display will then read:

03 D15:00 02 TOT HITS BOT<00>

Press [1][ENTER] to set the Home hits to 1.

4. **SET TOTAL ERRORS** – Press [SET TOTAL ERRORS]. The LCD display will read:

03 D15:00 02 TOT ERRS TOP<00>

Press [4][ENTER] to set the Visitor errors to 4. The LCD display will then read:

03 D15:00 02 TOT ERRS BOT<00>

Press [2][ENTER] to set the Home errors to 2.

5. **INC INNING T / B** – This key increments the inning to the next half inning. When the console is turned on, the LCD display will read:

03 D15:00 02 INNING -

Press [INC INNING T / B]. The LCD display will then read:

03 D15:00 03 INNING 01 TOP

The console is set to the top of the first inning. Pressing the key again increments the console to the bottom of the first inning.

6. **RUNS +1** – This key will increment the total runs by 1.
7. **HITS +1** – This key will increment the total hits by 1.
8. **ERRORS +1** – This key will increment the total errors by 1. The error will get counted against the team **NOT** at bat. For example, if the Visitor team is batting in the top of the first inning and an error is committed, then it would be charged against the Home team. Pressing [ERRORS +1] will increment the Home errors.
9. **BALLS +1** – This key will increment the Balls by 1.
10. **STRIKES +1** – This key will increment the Strikes by 1.
11. **OUTS +1** – This key will increment the Outs by 1.
12. **DIMMER** – This key will dim all the scoreboard lamps.
13. **NEW GAME** – This key can be used to reset all scoreboard functions. Press [NEW GAME] and the LCD display will read:

RESET	YES<1>
SCOREBOARD	NO<0>

Press [1][ENTER] to reset the scoreboard.

14. **SET RUNS / INNING** – This key is used to change the score in a previous inning. Press [SET RUNS / INNING] and the LCD display will read:

03	D15:00	02
RUNS-INNING		<05>

Press [3], [ENTER] to set the runs in the third inning. The LCD display will read:

03	D15:00	02
RUNS-TOP		<02>

Press [1], [ENTER] to change the score for the top of the third inning. The LCD display will read:

03	D15:00	02
RUNS-BOTTOM		<02>

Press [0], [ENTER] to change the score for the bottom of the third inning. **Note:** The total runs will not be updated automatically. You must use the SET TOTAL RUNS key to update this information.

15. **SET INNING T / B** – This key is used to change the current inning.. Press [SET INNING T / B] and the LCD display will read:

03	D15:00	02
SET TO INN	<02>	

Press [5], [ENTER] to change to the fifth inning. The LCD display will read:

03	D15:00	02
TOP=0/BOT=1	<00>	

Press [1], [ENTER] to select the bottom of the inning.

16. **CLEAR / FLASH HITS** – This key has two purposes. It can be used to clear incorrect keypad entries. It can also be used to flash the hit symbol (H) on the scoreboard.
17. **ENTER / FLASH ERRORS** – This key has two purposes. It is used when entering game information. It can also be used to flash the error symbol (E) on the scoreboard.

The SET CLOCK, SET CLOCK .1 SEC, .1 SEC ON / OFF, CLOCK UP / DOWN, AUTO HORN, TIME OF DAY, TIME OUT TIMER, HORN ON / OFF, and CLOCK ON/OFF keys are not used with the MP-158 scoreboard.

You should reset the scoreboard each time that it is turned on. Test out all the functions to ensure that the scoreboard is operating properly. **Electro-Mech Scoreboard Company strongly advises that you unplug the control console, disconnect the extension cable at the control console, and turn the power to the scoreboard off when the scoreboard is not in use. The control console can not turn the scoreboard off.** This action will help protect the scoreboard and control console from power surges and lightning strikes.

SERVICING THE SCOREBOARD

While your scoreboard was designed for years of trouble-free operation, some problems may occasionally occur. Our trained personnel at Electro-Mech Scoreboard Company are ready to answer your questions from Monday to Friday during the hours of 8 AM to 5 PM Eastern Standard Time. Be sure to know your scoreboard model number when calling. Scoreboard replacement parts, including lamps, are always available. Electro-Mech Scoreboard Company can repair the control console and plug in modules at a significant savings when compared to the price of new units. Our convenient toll free number is listed at the bottom of every page in this manual.

Figure 13 shows the components behind the middle access panel.

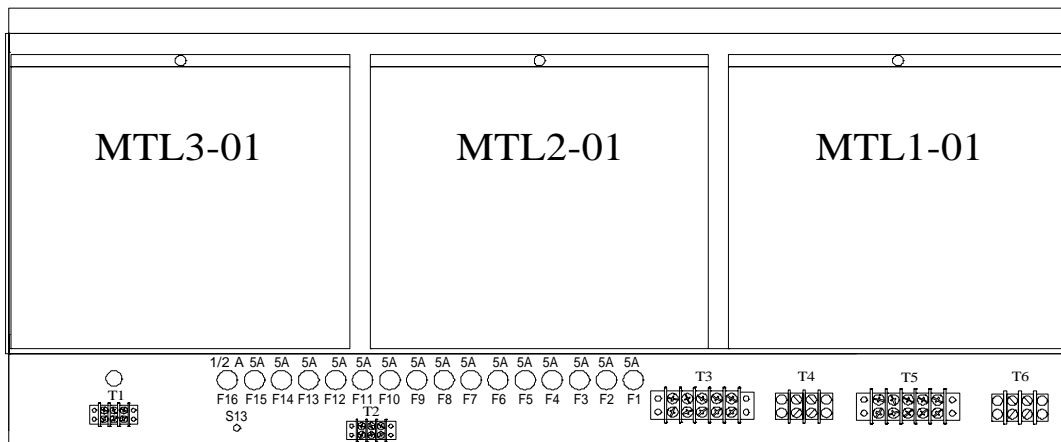

Figure 13 Middle Access Panel Components

Plug in module MTL3-01 operates VISITOR RUNS, HITS, and ERRORS. Plug in module MTL2-01 operates the VISITOR runs for innings 6 through 10. Plug in module MTL1-01 operates the VISITOR runs for innings 1 through 5.

FUSES

FUSE	RATING	FUNCTION
F1	5 A 250 V	VISITOR INNING 1
F2	5 A 250 V	VISITOR INNING 2
F3	5 A 250 V	VISITOR INNING 3
F4	5 A 250 V	VISITOR INNING 4
F5	5 A 250 V	VISITOR INNING 5
F6	5 A 250 V	VISITOR INNING 6
F7	5 A 250 V	VISITOR INNING 7
F8	5 A 250 V	VISITOR INNING 8
F9	5 A 250 V	VISITOR INNING 9
F10	5 A 250 V	VISITOR INNING 10
F11	5 A 250 V	VISITOR RUNS UNITS
F12	5 A 250 V	VISITOR RUNS TENS
F13	5 A 250 V	VISITOR HITS UNITS
F14	5 A 250 V	VISITOR HITS TENS
F15	5 A 250 V	VISITOR ERROR
F16	1/2 A 250 V	CONTROL LINE

CONNECTION POINTS

TERMINAL STRIP	FUNCTION
T-1	control cable connection
T-2	control cable to bottom access panel
T-3	MOV (surge protection)
T-4	power cable connection
T-5	power to top access panel
T-6	power to bottom access panel
S-13	test jack

Figure 14 shows the components behind the bottom access panel.

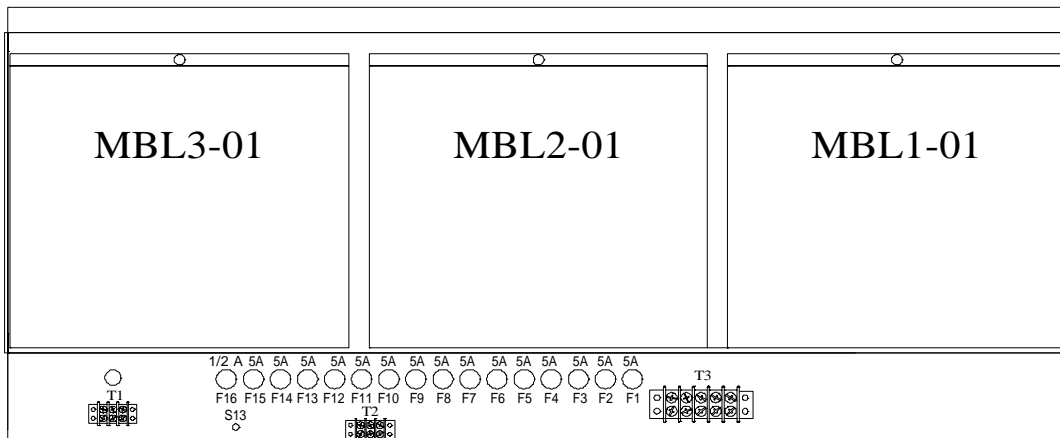

Figure 14 Bottom Access Panel Components

Plug in module MBL3-01 operates HOME RUNS, HITS, and ERRORS. Plug in module MBL2-01 operates the HOME runs for innings 6 through 10. Plug in module MBL1-01 operates the HOME runs for innings 1 through 5.

FUSES

FUSE	RATING	FUNCTION
F1	5 A 250 V	HOME INNING 1
F2	5 A 250 V	HOME INNING 2
F3	5 A 250 V	HOME INNING 3
F4	5 A 250 V	HOME INNING 4
F5	5 A 250 V	HOME INNING 5
F6	5 A 250 V	HOME INNING 6
F7	5 A 250 V	HOME INNING 7
F8	5 A 250 V	HOME INNING 8
F9	5 A 250 V	HOME INNING 9
F10	5 A 250 V	HOME INNING 10
F11	5 A 250 V	HOME RUNS UNITS
F12	5 A 250 V	HOME RUNS TENS
F13	5 A 250 V	HOME HITS UNITS
F14	5 A 250 V	HOME HITS TENS
F15	5 A 250 V	HOME ERROR
F16	1/2 A 250 V	CONTROL LINE

CONNECTION POINTS

TERMINAL STRIP	FUNCTION
T-1	control cable from middle access panel
T-2	control cable to top access panel
T-3	power from middle access panel
S-13	test jack

Figure 15 shows the components behind the top access panel. The plug in module MBAT-01 operates BALL, STRIKE, OUT BATTER NUMBER, HIT, and ERROR.

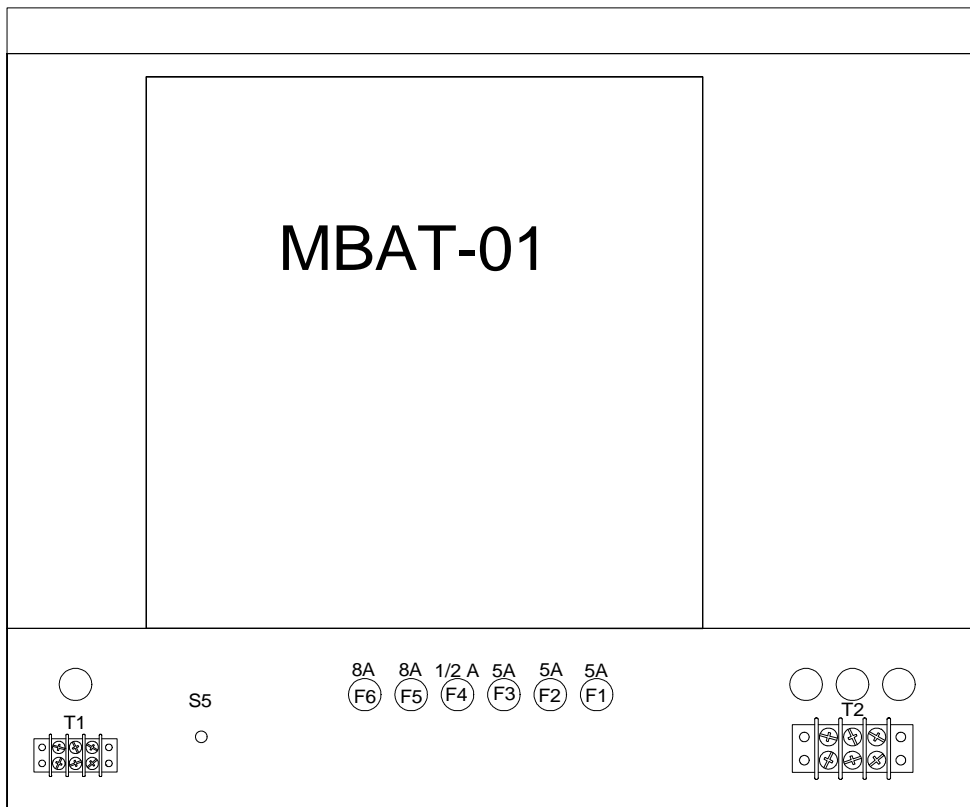

Figure 15 Top Access Panel Components

FUSES

FUSE	RATING	FUNCTION
F1	5 A 250 V	BALL
F2	5 A 250 V	STRIKE
F3	5 A 250 V	OUT
F4	1/2 A 250 V	CONTROL LINE
F5	8 A 250 V	BATTER NUMBER
F6	8 A 250 V	HIT and ERROR

CONNECTION POINTS

TERMINAL STRIP	FUNCTION
T-1	control cable from bottom access panel
T-2	power cable from middle access panel
S-5	test jack

PLUG IN MODULE REPLACEMENT

Each module has four bottom plugs which mate with sockets in the scoreboard. A screw located at the top of the module holds it against the scoreboard cabinet. Simply remove the screw and pull the module upward to unseat the module. **To avoid damage to the plug in module, always turn off the power to the scoreboard when removing or replacing it.**

LAMP REPLACEMENT

Replacing lamps may be the only service you ever perform on your Electro-Mech scoreboard. The lamps are accessed by removing the protective mask covering each lamp bank. **To avoid damage to the plug in module, always turn off the power to the scoreboard when changing lamps.** We recommend using a felt pen or tape to mark lamps that will not light. This scoreboard uses 15 watt medium base lamps (also called 15A15 lamps). **Never replace these with higher wattage lamps.**

ELECTRO-MECH SCOREBOARD CO. FIVE YEAR LIMITED WARRANTY

THE ELECTRICAL COMPONENTS OF ALL ELECTRO-MECH SCOREBOARDS ARE GUARANTEED FOR A PERIOD OF FIVE (5) YEARS FROM THE DATE OF INVOICE AGAINST DEFECTS IN WORKMANSHIP OR MATERIAL AND WILL BE REPLACED OR REPAIRED WITHOUT COST TO THE OWNER PROVIDED THE EQUIPMENT OR PARTS ARE RETURNED POSTAGE-PAID TO THE FACTORY IN WRIGHTSVILLE, GA. SHIPPING BACK TO THE OWNER WILL BE VIA UPS GROUND SERVICE EXCEPT WHEN AIR OR SPECIAL METHOD OF RETURN IS SPECIFIED BY THE OWNER, IN WHICH CASE SHIPPING WILL BE FREIGHT COLLECT.

EXCLUDED FROM THIS WARRANTY ARE LAMPS, FUSES AND SOCKETS.

THIS WARRANTY DOES NOT INCLUDE LABOR CHARGES INCURRED IN THE REMOVAL OF COMPONENT PARTS, SERVICE CALLS, OR DAMAGES RESULTING FROM IMPROPER INSTALLATION, IMPROPER OPERATION, OR PROBLEMS CAUSED BY ANY REPAIR, ALTERATION OR MODIFICATION OF THE SCOREBOARD NOT PERFORMED BY ELECTRO-MECH.

EQUIPMENT WHICH IS SUBJECTED TO ACCIDENT, NEGLIGENCE, ABUSE, MISUSE OR OTHER NATURAL DISASTERS, INCLUDING BUT NOT LIMITED TO FIRE, WIND, LIGHTNING, OR FLOOD, IS NOT COVERED BY THIS GUARANTEE.