

ELECTRO-MECH SCOREBOARD CO.

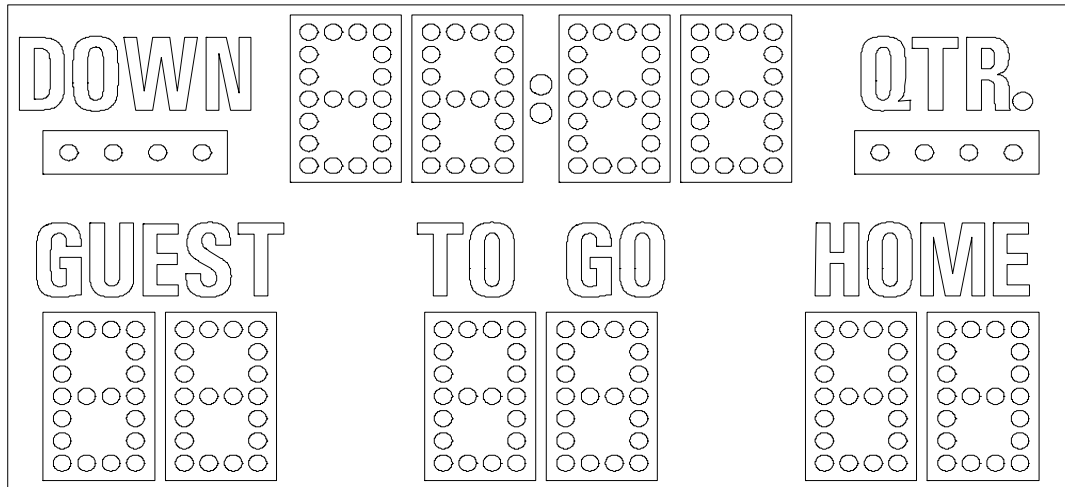

MM-335 FOOTBALL SCOREBOARD

OWNER'S HANDBOOK

Thank you for choosing an Electro-Mech Scoreboard for your athletic complex. We are confident that your new scoreboard will give many years of reliable service.

Rev. 1 Revised: 07/29/05

TABLE OF CONTENTS

MM-335 SCOREBOARD SPECIFICATIONS	3
SCOREBOARD INSTALLATION	4
MECHANICAL INSTALLATION	4
Post Installation.....	4
Mounting The Scoreboard	7
MOUNTING HARDWARE	8
Mounting The Optional Top Sponsor Panel	9
ELECTRICAL INSTALLATION	10
Ground Connection	10
Horn Installation.....	13
ScoreLink 300.....	13
Control Cable Installation.....	14
Control Console Connections	15
Control Console Safety Warning.....	15
SCOREBOARD OPERATION.....	16
SCOREBOARD STARTUP	16
GAME TIME OPERATION.....	16
Control Console Key Functions.....	17
SCOREBOARD SHUTDOWN.....	17
SERVICING THE SCOREBOARD.....	18
COMPONENT REPLACEMENT	18
Lamp Replacement	18
PLUG-IN MODULE REPLACEMENT.....	19
WARRANTY	20

MM-335 SCOREBOARD SPECIFICATIONS

GENERAL: This ETL listed scoreboard includes the scoreboard cabinet, a horn, mounting hardware, control console, 10 ft. extension cable, and junction box.

DIMENSIONS: 10' L x 5' H x 6" D

WEIGHT: 185 lbs

SCOREBOARD CONSTRUCTION: The outer frame is made from extruded aluminum. Internal structural parts may be extruded aluminum or formed from aluminum sheet. The face and back are made from aluminum sheet. The face and masks are finished with enamel paint. Black is the standard color. The captions are white exterior grade vinyl.

DISPLAY: The MM-335 scoreboard displays HOME and GUEST scores to 99, TIME to 90 minutes, TO GO to 60, DOWN, and QTR.

LAMP BANKS: A 4 x 7 matrix of lamps forms each 18" digit. Four lamps form the DOWN indicator and four lamps form the QTR. indicator. The scoreboard uses 15 watt 120 VAC frosted medium based appliance lamps (also known as 15A15IF lamps). Recessed aluminum reflectors provide a crisp separation between each lamp. Expanded metal screens protect the lamps.

POWER REQUIREMENTS: **Scoreboard** - 120 VAC, 26 A, 60 Hz. The scoreboard may be connected to either 120 VAC or 240 VAC single phase. **Control Console** - 120 VAC, 0.5 A, 60 Hz

SCOREBOARD ELECTRONICS: 100% solid state fully enclosed within 2 plug-in modules.

CONTROL CONSOLE: The control console features a microprocessor, 15 key sealed membrane keypad, and an attached 6 foot power cord. The console housing consists of ABS plastic base and top pieces with a steel back plate.

CONTROL CABLE: The cable has two 22 AWG stranded copper conductors with semi-rigid PVC insulation. It also has a braided shield and a foil shield. The polyethylene jacket is rated at 300 volts. The cable is direct burial rated and measures approximately 1/4" in diameter. This item is sold separately from the scoreboard.

JUNCTION BOX AND EXTENSION CABLE: A 4 1/4" x 2 1/4" x 2" junction box with a 1/4" stereo jack mounted on the face plate is attached to the control cable at the point of operation. A 10 ft. extension cable connects the control console to the junction box.

SCORELINK 300 RF MODEM SYSTEM: This accessory can be used in place of control cable and junction box for this scoreboard without internal modifications to the scoreboard or the control console. Refer to the SCORELINK 300 RF MODEM SYSTEM OWNER'S HANDBOOK for more information.

WARRANTY: Five year limited warranty.

SCOREBOARD INSTALLATION

This part of the manual describes the mechanical and electrical installation of the scoreboard.

One of the items listed below must be purchased in order to complete the installation:

- Control cable (length dependent upon installation site layout)
- ScoreLink 300 RF Modem System

Items not provided by Electro-Mech Scoreboard Company that are necessary for installation:

- Two posts
- Power cable to connect the scoreboard to the power source
- Grounding hardware
- A grounded NEMA 5-15R 120 VAC receptacle for the control console at the scorekeeper's table.

Items not provided that are recommended by Electro-Mech Scoreboard Company for installation:

- A weatherproof power disconnect at the scoreboard

Electro-Mech Scoreboard Company performs installations in some areas. In other areas, we can help you contact an independent installer. In areas in which installation service is not available from Electro-Mech Scoreboard Company, we will make every effort to answer your installation questions. Qualified personnel should perform the scoreboard installation. Consult national and local codes before installation.

MECHANICAL INSTALLATION

The mechanical installation includes installing the posts and mounting the scoreboard and the optional sponsor panels (if purchased) to the posts.

Post Installation

The scoreboard mounts on two posts. Typically installers will use steel pipes or I-beams. In order to reduce the glare from the sun on the front of the scoreboard, position the posts so that the front of the scoreboard is angled away from the afternoon sun, if possible. The mounting hardware will accommodate posts up to 4.5 inches outer diameter. Sink the posts in reinforced concrete footings. Figure 1 shows the spacing of the posts for the MM-335 scoreboard. The specifications for the posts and concrete footings are dependent upon the expected local wind and soil conditions, the height of the scoreboard from the ground, and the local building codes. Electro-Mech Scoreboard Company assumes no responsibility for the installation of scoreboards by others.

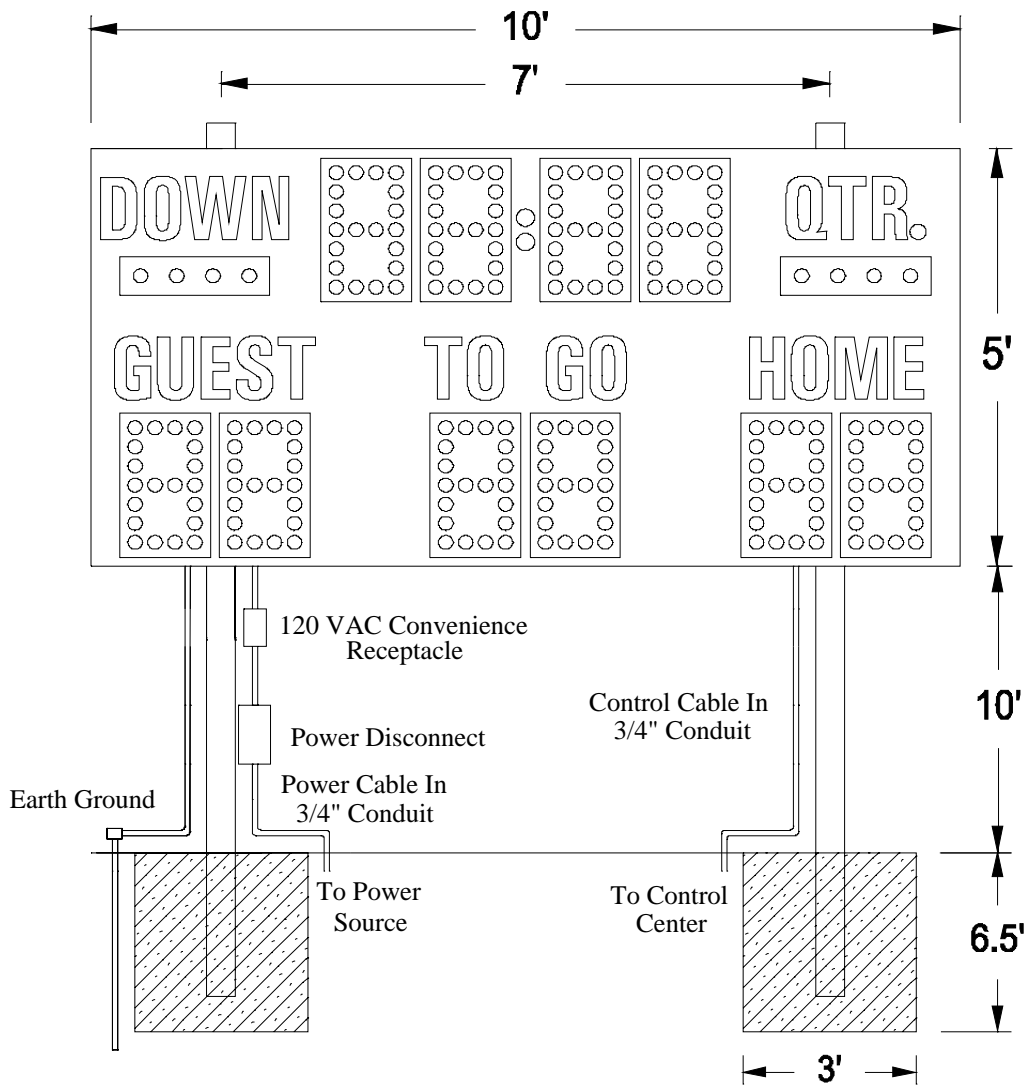

Figure 1 MM-335 Post Spacing

Figure 2 shows the spacing of the posts for a MM-335 with an optional top sponsor panel.

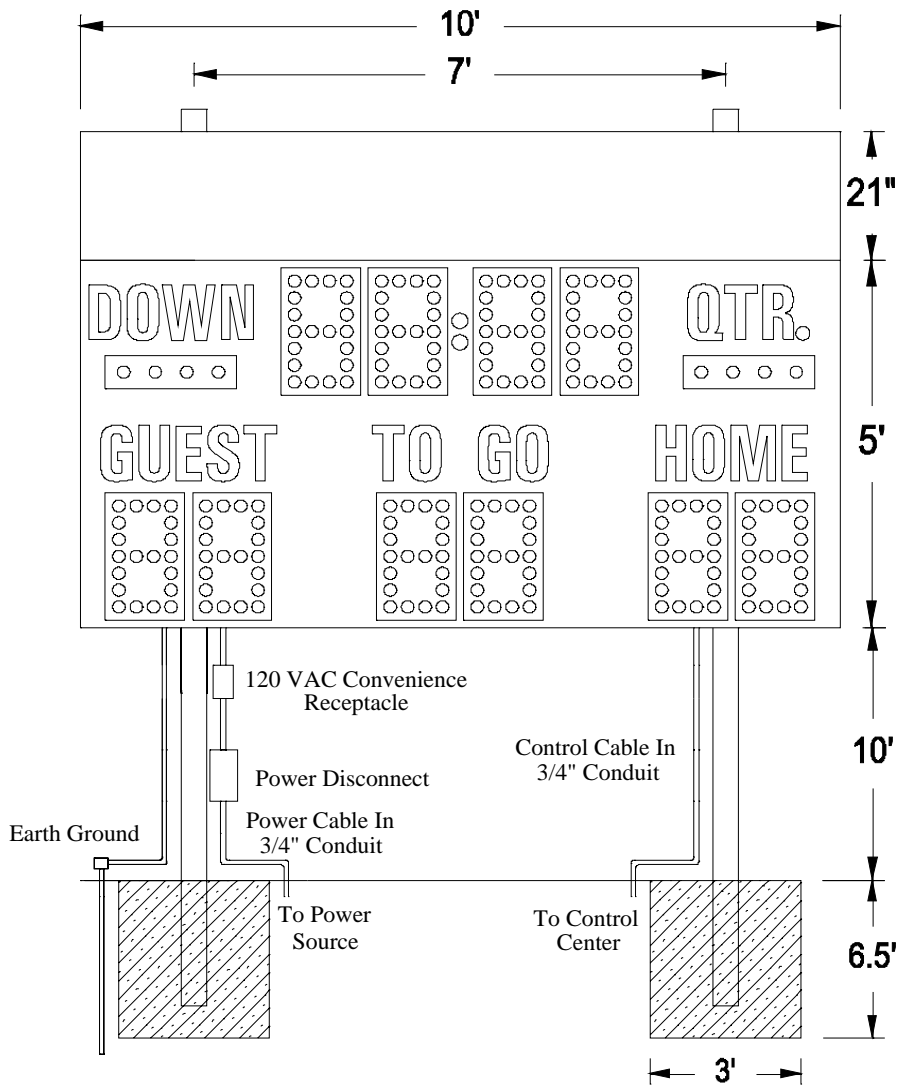

Figure 2 MM-335 with Optional Top Sponsor Panel Post Spacing

Figure 3 shows the spacing of the posts for a MM-335 with an optional side sponsor panel.

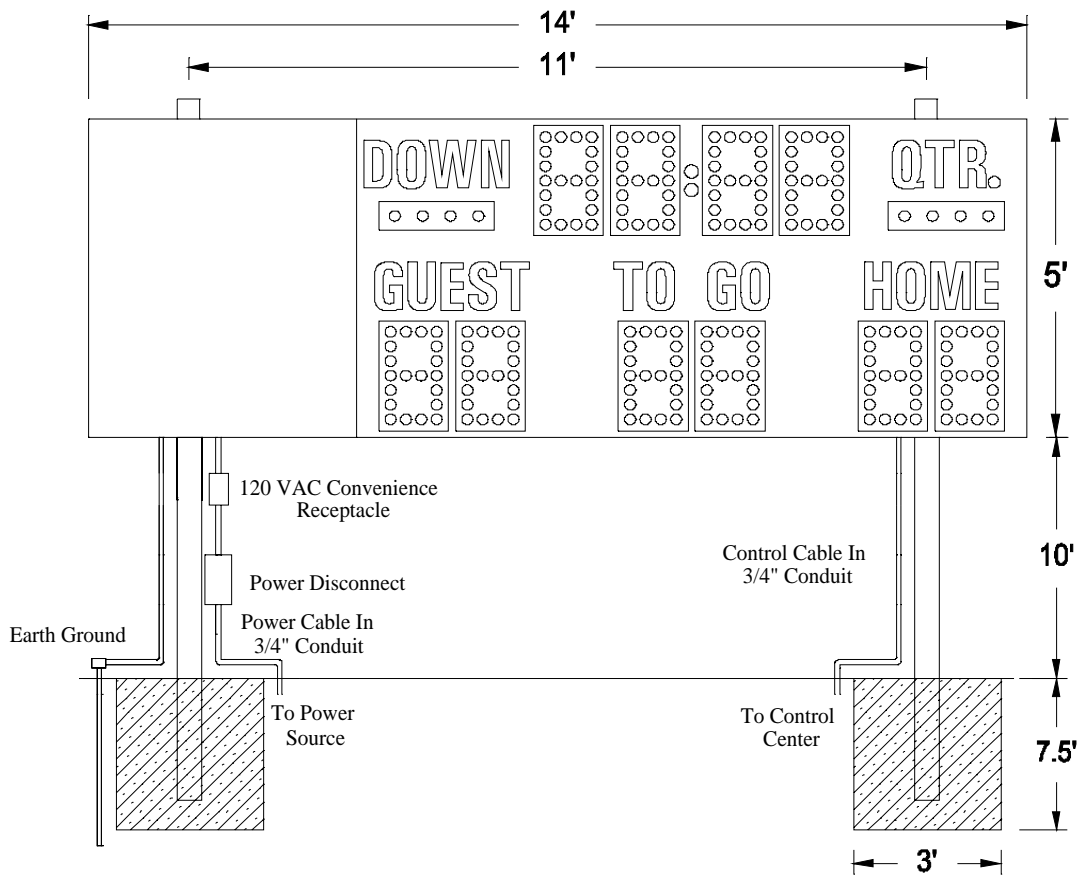

Figure 3 MM-335 with Optional Side Sponsor Panel Post Spacing

Mounting The Scoreboard

The scoreboard is attached to the posts at four points. Figure 4 shows the location of the mounting points on the rear of the scoreboard.

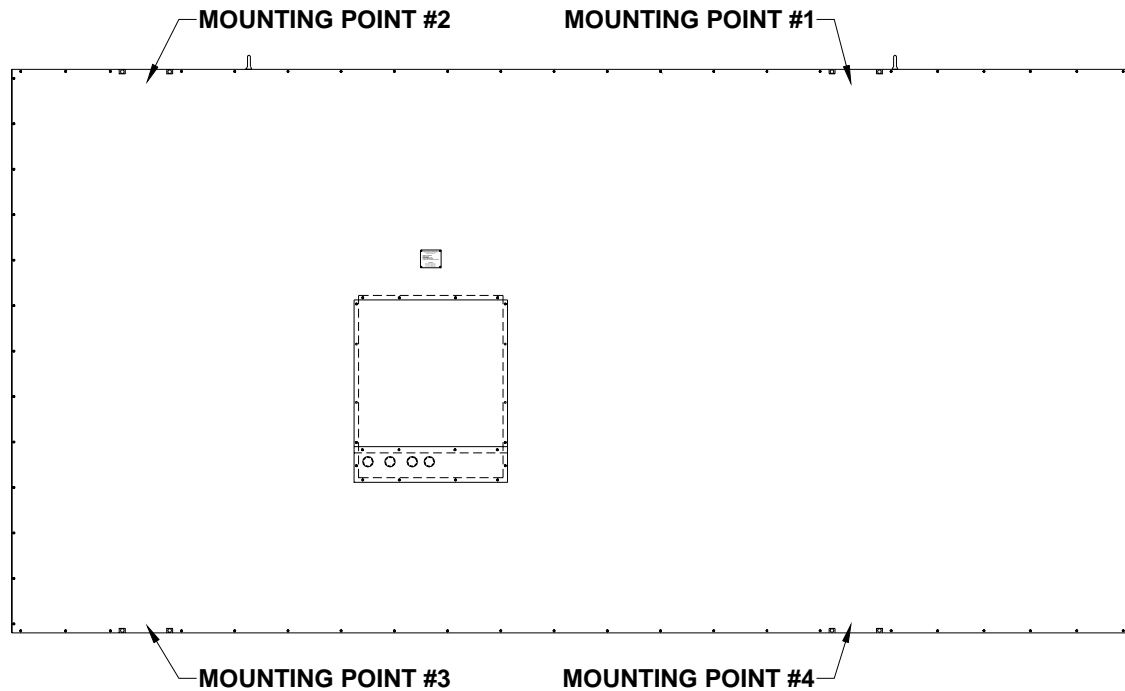

Figure 4 Mounting Points

MOUNTING HARDWARE

Four sets of mounting hardware are provided to attach the scoreboard at these points. Additional hardware sets are provided to attach the optional sponsor panels, if ordered. A single set of mounting hardware for the scoreboard or an optional side sponsor panel consists of a steel angle bracket, two threaded rods, two washers, and two nuts. A single set of mounting hardware for an optional top sponsor panel consists of a steel angle bracket, two threaded rods, four washers, and four nuts. Figure 5 shows an overhead cross section view and a side cross section view of the scoreboard attached to a post at a mounting point. A steel bar is riveted inside the scoreboard's aluminum extrusion frame. The bar has two tapped holes. The threaded rods screw into these tapped holes. The washers and nuts are used to clamp the steel angle bracket against the steel post and hold the scoreboard in place.

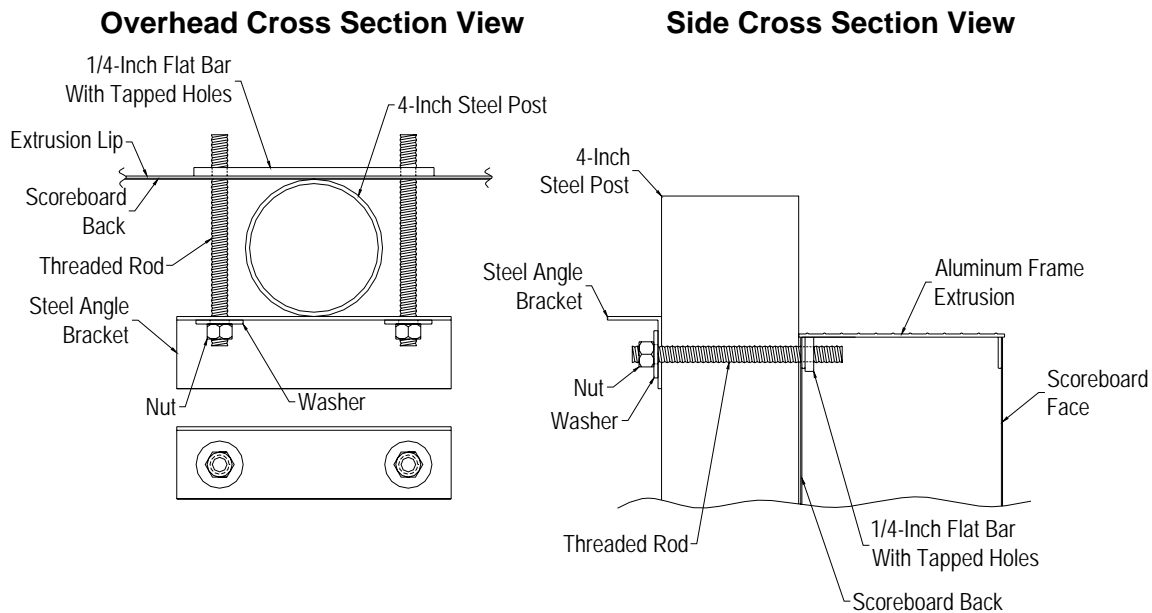

Figure 5 Standard Mounting Method

The following steps describe how to mount the scoreboard on the posts:

1. Place the scoreboard cabinet against the posts on the ground. Make sure the mounting points are aligned with the posts.
2. Screw the threaded rods into the tapped holes in the scoreboard.
3. Place a steel angle bracket over the threaded rods at mounting point #1.
4. Place a washer over each threaded rod.
5. Screw the nuts onto the threaded rods so that the bracket is loosely held in place.
6. Repeat steps 3 - 6 at the other mounting points.
7. Raise the scoreboard into place and tighten the nuts to clamp the scoreboard in place on the posts.

Mounting The Optional Top Sponsor Panel

Additional hardware sets are provided to attach the optional top sponsor panels, if purchased. The following steps describe how to mount the top sponsor panel on the posts:

1. Raise the top sponsor panel in place above the scoreboard. Make sure the mounting points are aligned with the posts.
2. Place the threaded rods through the mounting holes in the top sponsor panel at one mounting point.
3. Place a washer over each threaded rod inside the frame of the top sponsor panel, and screw a nut onto each threaded rod behind the washers inside the frame of the top sponsor panel.
4. Place a steel angle bracket over the threaded rods at a mounting point.

5. Place a washer over each threaded rod.
6. Screw a nut onto each threaded rod so that the bracket is loosely held in place.
7. Repeat steps 2 - 6 at the other mounting points.
8. Tighten the nuts to clamp it in place on the posts.

ELECTRICAL INSTALLATION

We recommend a qualified electrician perform the needed electrical connections to ensure proper operation of the scoreboard. These connections include grounding the scoreboard, installing the horn, connecting the scoreboard to a power source, installing the ScoreLink 300 or the control cable, and connecting the control console.

Ground Connection

The National Electrical Code **requires** a scoreboard (electric sign) to be grounded. Grounding the scoreboard helps the scoreboard electronics operate properly and helps minimize damage if it is struck by lightning. Metal posts do **not** provide an adequate ground path. The following steps describe how to connect the scoreboard to the power source:

1. Drive one or more 5/8" x 8' copper clad ground rods in the soil near the scoreboard.
2. Connect #6 bare copper wire to the ground rods using 5/8" brass tear drop connectors.
3. Remove the rear access panel and the dome plugs on the plate below the access panel. Figure 6 shows the location of the access panel and the dome plugs.

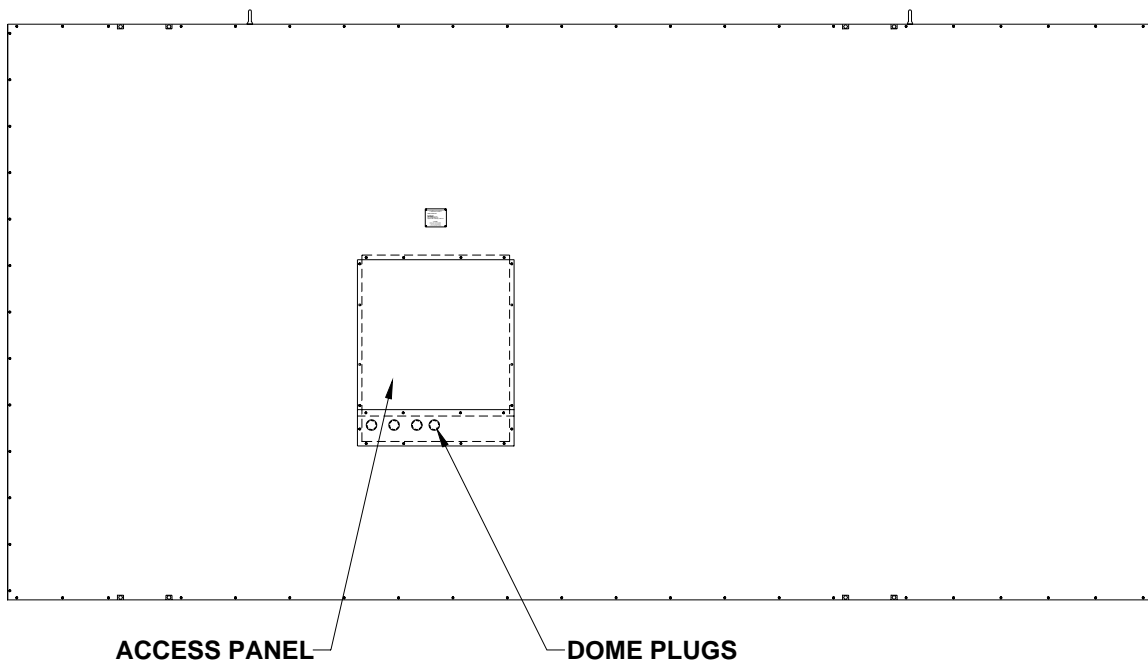

Figure 6 Rear Access Panel

4. Figure 7 shows the view behind the access panel.

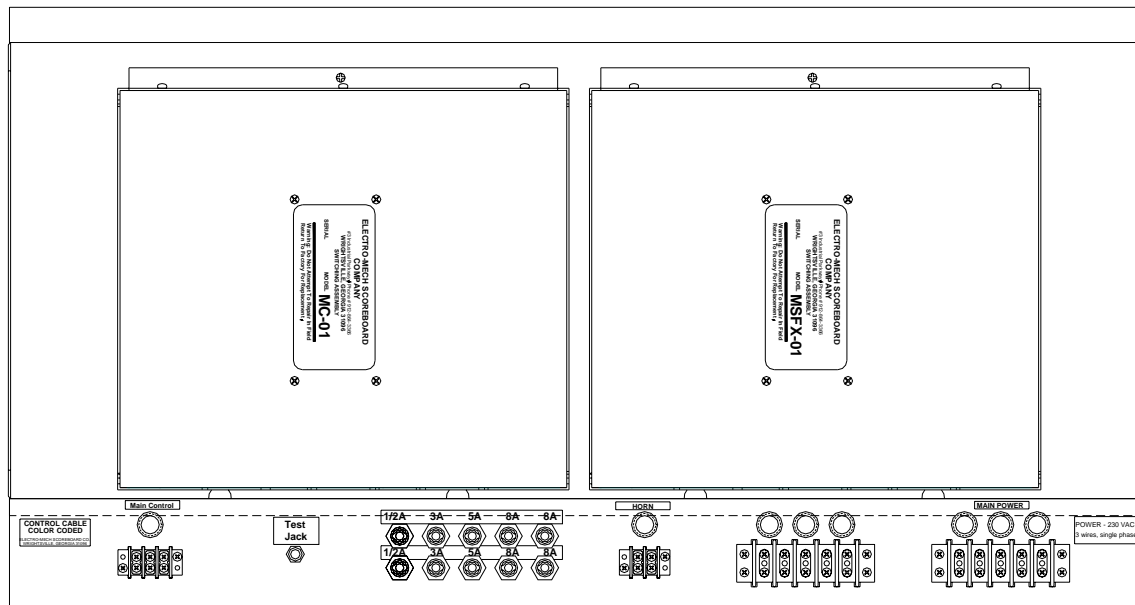

Figure 7 Access Panel Removed

2. Pass the power cables through a hole in the plate below the access panel.
3. If you are going to connect the scoreboard to a 240 VAC supply, connect one AC line wire to position 2, AC neutral wire to position 3, and the other AC line wire to position 4 of **Main Power** terminal block on the junction chassis according to figure 8.

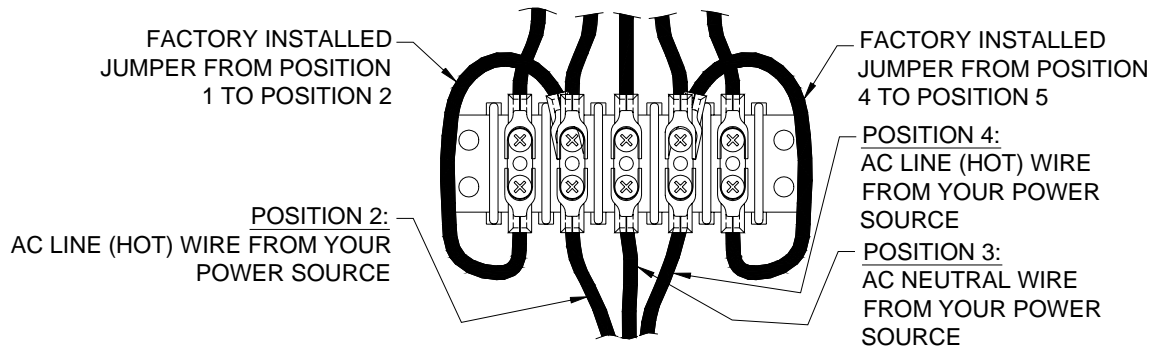

Figure 8 240 VAC Connections

- If you are going to connect the scoreboard to a 120 VAC supply, connect the AC line wire to position 2 and the AC neutral wire to position 3 of **Main Power** terminal block on the junction chassis. Add a jumper from position 2 to position 4. **This jumper is not provided.** Refer to figure 9.

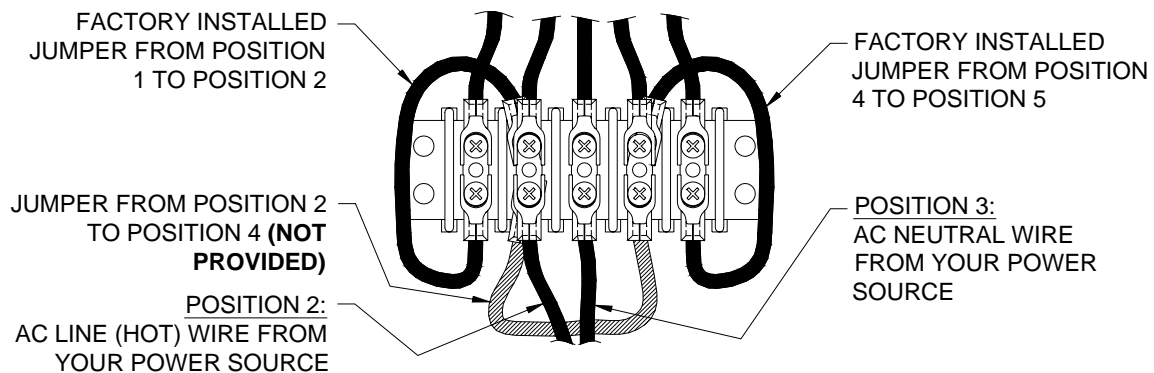

Figure 9 120 VAC Connections

Electro-Mech Scoreboard Company suggests that you install a power cut-off switch and a NEMA 5-15R receptacle in a weatherproof box on the scoreboard post below the scoreboard. The cut-off switch provides a convenient way of turning the scoreboard off during maintenance or repairs. The NEMA 5-15R receptacle will allow a technician to easily plug in the control console and operate the scoreboard via the **Test Jack** (a valuable trouble-shooting aid).

Horn Installation

The items provided to install the horn are the horn, the mounting bolt, and the mounting bracket. Items which are not provided but are necessary for proper installation are ¾" conduit, two ¾" male conduit connectors, a ¾" straight male conduit connector, two wires, two forked crimp terminals, and two butt splice connectors. The electrical requirements for the horn are 0.35 A 120 VAC. The horn is mounted to the top of the scoreboard. If a horn was purchased with the scoreboard, a tapped hole is provided to fasten the horn to the scoreboard. The mounting bolt is screwed into the tapped hole at the factory. The following steps describe the assembly and mounting of the horn:

1. Cut a piece of ¾" conduit of sufficient length to reach from the horn mounting point to one of holes in the plate below the access panel.
2. Attach the conduit connectors to the ends of the conduit.
3. Cut two pieces of wire of approximately 4 feet longer than the conduit.
4. Push the wires through the conduit.
5. Peel the tape off the horn projector.
6. Remove the plastic bag from inside the horn projector.
7. Remove the four screws that fasten the horn and horn projector to the weatherproof back box.
8. Feed the two wire leads that are attached to the rear side of the horn through one of the threaded holes on the side of the weatherproof back box. Two of the holes will accept a ¾" conduit connector.
9. Plug the other two threaded holes with the plugs from the plastic bag.
10. Splice the horn wire leads to the two wires that run through the conduit with the butt splice connectors.
11. Screw the conduit connector into the threaded hole on the weatherproof back box.
12. Attach the horn and horn projector to the weatherproof back box using the four screws.
13. Fasten the horn assembly to the scoreboard using the mounting bolt from the scoreboard.
14. Crimp forked terminals on the ends of the two wires that protrude out of the other end of the conduit.
15. Pass the wires through one of holes in the plate below the access panel.
16. Fasten the conduit connector to the plate and connect the wires to the **HORN** terminal block on the junction chassis. Connect the AC-L wire to the left terminal and the AC-N wire to the right terminal.

ScoreLink 300

The ScoreLink 300 RF MODEM SYSTEM is designed to eliminate the control cable between the scoreboard and the control console on Electro-Mech Scoreboard MM and

MP series scoreboards as well as all LED scoreboards. If you have purchased this accessory, disregard the section of this manual titled **Control Cable Installation**. Refer to the ScoreLink 300 RF MODEM SYSTEM OWNER'S HANDBOOK for installation instructions.

Control Cable Installation

The control cable connects the scoreboard to the control console. Install the control cable in conduit. If the cable is ever damaged, it is easier and less expensive to replace a cable in conduit. A small junction box with a ¼" stereo jack mounted on the face plate is attached to the control cable at the point of operation of the scoreboard. This junction box should be securely mounted in a clean, dry area within ten feet of the rear of the control console. Most customers order the control cable with the junction box attached. Some customers prefer to attach the junction box after the cable is installed. Those customers must solder the control cable to the ¼" stereo jack. Figure 10 shows the control cable wire connection points on the rear of the ¼" stereo jack.

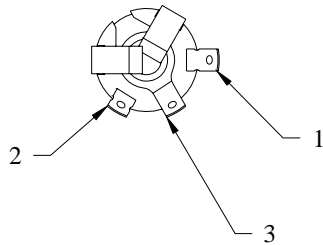

PIN 1 - BLACK WIRE
PIN 2 - RED WIRE
PIN 3 - SHIELD WIRE

Figure 10 ¼" Stereo Jack Wiring Diagram

The following steps describe how to connect the control cable to the scoreboard:

1. At the rear of the scoreboard feed the control cable through the left hole in the plate below the access panel.
2. Crimp fork terminals to the control cable wires and the shield.
3. Connect the control cable to **Main Control** terminal block on the junction chassis according to figure 11.

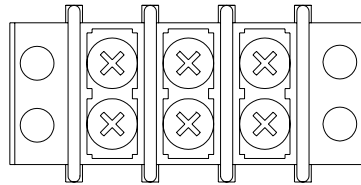

BLACK RED SHIELD
WIRE WIRE WIRE

Figure 11 Control Cable Wiring Diagram

4. Reinstall the access panel.

Control Console Connections

The 10 ft. extension cable has two molded ¼” stereo plugs attached to it. It is used to connect the control console to the junction box. The following steps describe how to connect the control console:

1. Plug one end of the extension cable into ¼” stereo jack on the junction box or the ScoreLink 300 Transmitter, if purchased.
2. Plug the other end into the ¼” stereo jack mounted on the control console back plate.
3. Plug the control console power cord into a grounded NEMA 5-15R 120 VAC receptacle.

Control Console Safety Warning

This product is equipped with a 3-wire grounding type plug, a plug having a third (grounding) pin. This plug will only fit into a grounding-type power outlet. This is a safety feature. If you are unable to insert the plug into the outlet, contact a qualified electrician to replace your obsolete outlet. Do not defeat the purpose of the grounding-type plug.

SCOREBOARD OPERATION

SCOREBOARD STARTUP

1. Place the power disconnect for the scoreboard in the **ON** position.
2. Plug one end of the extension cable into ¼" stereo jack on the junction box or the ScoreLink 300 Transmitter, if purchased.
3. Plug the other end into the ¼" stereo jack mounted on the control console back plate.
4. Plug the control console power cord into a grounded NEMA 5-15R 120 VAC receptacle.
5. If a ScoreLink 300 RF MODEM SYSTEM is installed with this scoreboard, plug the wall mount DC power supply into a grounded NEMA 5-15R 120 VAC receptacle and the male plug on the end of the attached cable into the Power jack on the Transmitter.

GAME TIME OPERATION

This scoreboard is operated with a 15-key control console. Figure 12 shows the keypad layout on the control console.

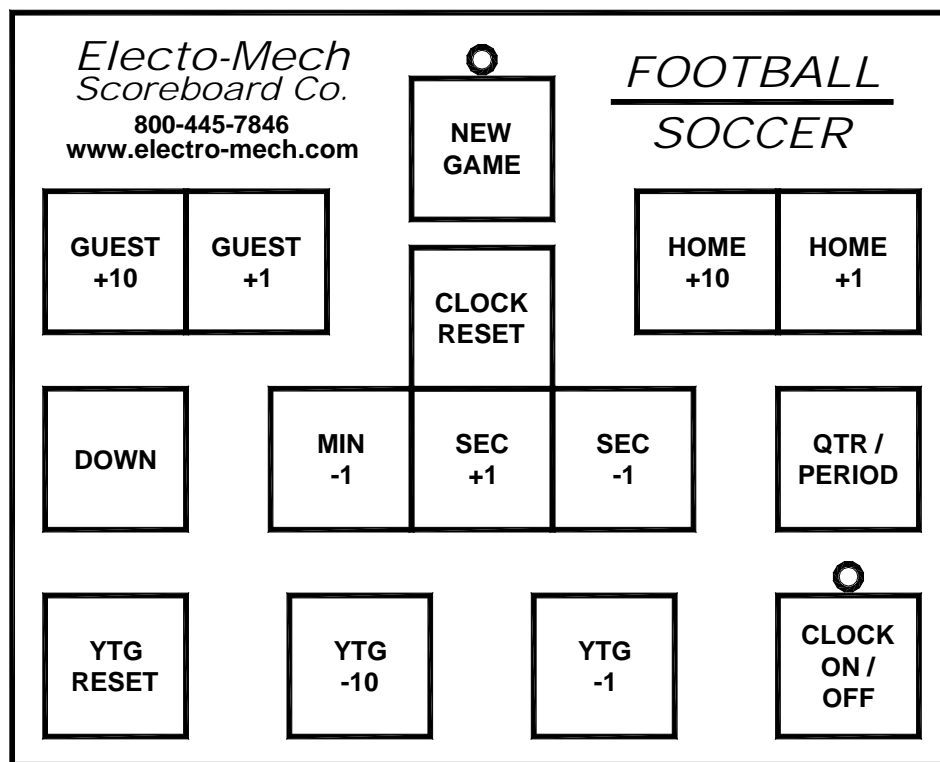

Figure 12 Keypad Layout

The scoreboard will display:
 GUEST SCORE – 0
 HOME SCORE – 0
 CLOCK – 15:00

Control Console Key Functions

1. **GUEST +1** – This key increments the Guest score by 1.
2. **HOME +1** – This key increments the Home score by 1.
3. **GUEST +10** – This key increments the Guest score by 10.
4. **HOME + 10** – This key increments the Home scores by 10.
5. **DOWN** – This key increments the DOWN by 1.
6. **QTR / PERIOD** – This key increments the quarter indicator by 1.
7. **YTG RESET** – This key resets the Yards To Go to 60. This key must be used to initially display Yards To Go on the scoreboard.
8. **YTG -10** – This key decrements the Yards To Go by 10.
9. **YTG -1** – This key decrements the Yards To Go by 1.
10. **CLOCK ON/OFF** – This key toggles the clock on and off. When the clock is on, a red LED on the keypad above this key is illuminated. The horn sounds for two seconds when the game clock reaches 0 seconds.
11. **MIN -1** – This key decreases the clock by one minute.
12. **SEC +1** – This key increases the clock by one second.
13. **SEC -1** – This key decreases the clock by one second.
14. **CLOCK RESET** – This key is used to cycle the clock between the 15, 30, 60, and 90 minutes settings.
15. **NEW GAME** – This key can be used to reset all scoreboard functions. Press **NEW GAME** and, within two seconds, press **CLOCK RESET**.

You should reset the scoreboard each time that it is turned on. Test out all the functions to ensure that the scoreboard is operating properly.

SCOREBOARD SHUTDOWN

1. Place the power disconnect for the scoreboard in the **OFF** position.
2. Unplug the control console power cord.
3. Unplug the extension cable.
4. If a ScoreLink 300 RF MODEM SYSTEM is installed with this scoreboard, unplug the Transmitter's wall mount power supply.
5. Store the control console and ScoreLink 300 Transmitter in a dry location. These units are not waterproof.

Proper scoreboard shutdown will help protect the scoreboard and control console from power surges and lightning strikes.

SERVICING THE SCOREBOARD

While your scoreboard was designed for years of trouble-free operation, some problems may occasionally occur. Electro-Mech Scoreboard Company offers onsite service in some areas. In other areas, we can help you contact an independent service technician. In areas in which service is not available from Electro-Mech Scoreboard Company, we will make every effort to answer your questions. Our trained personnel at Electro-Mech Scoreboard Company are ready to answer your questions from Monday to Friday during the hours of 8 AM to 5 PM Eastern Standard Time. Be sure to know your scoreboard model number when calling. Scoreboard replacement parts are always available. Damaged parts can usually be repaired at a significant cost savings. Our convenient toll free number is listed at the bottom of every page in this manual.

COMPONENT REPLACEMENT

Lamp Replacement

Remove the protective mask covering each lamp bank to access the lamps. **To avoid damage to the plug-in module, always turn off the power to the scoreboard when changing lamps.** We recommend using a felt pen or tape to mark lamps that will not light. The scoreboard uses 15 watt 120 VAC frosted medium based appliance lamps (also known as 15A15IF lamps). **Never replace these with higher wattage lamps.**

All other components are located behind the rear access panel. Figure 13 shows the view behind the access panel.

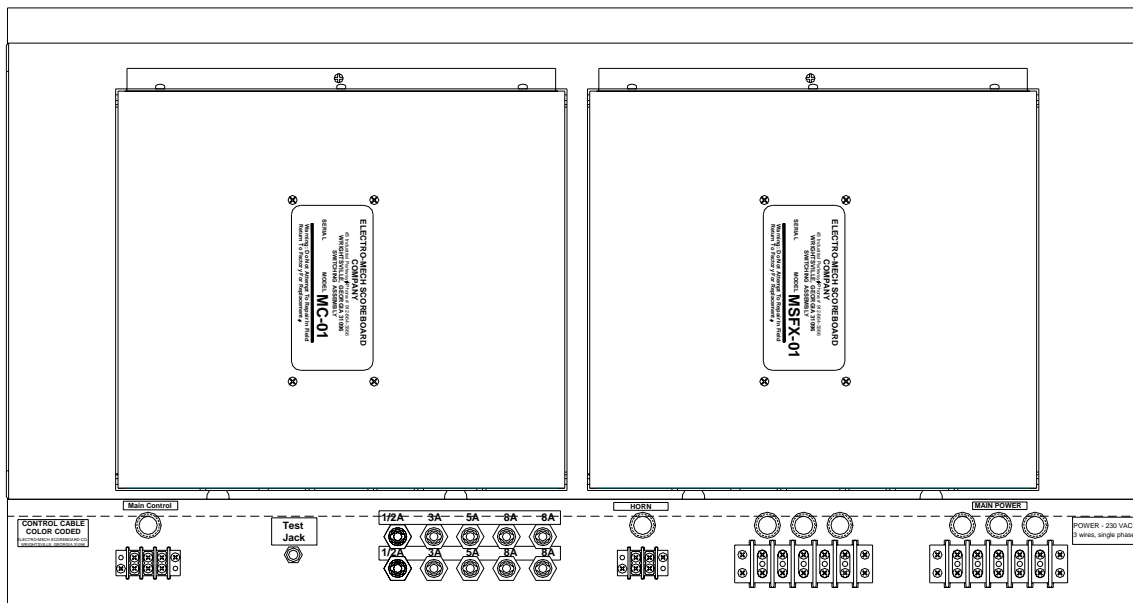

Figure 13 Access Panel Components

The electronics that control functions in the scoreboard are enclosed in two plug-in modules. The plug-in module MSFX-01 operates VISITOR SCORE, HOME SCORE, TO GO tens digit, DOWN, and QTR. The plug-in module MC-01 operates the CLOCK, TO GO units digit and the horn. The **Main Power, HORN, and Main Control** connection points are located on the junction chassis behind the access panel. The tables below list the fuses and electrical connection points that are mounted on the junction chassis. Always replace the fuses with replacements of the same type and rating.

PLUG-IN MODULE REPLACEMENT

Each module has bottom plugs that mate with sockets in the scoreboard. A screw located at the top of the module holds it against the scoreboard cabinet. Remove the screw and pull the module upward to unseat the module. **To avoid damage to the plug-in module, always turn off the power to the scoreboard when removing or replacing it.**

FUSES

FUSE	RATING	FUNCTION
F1	1/2 A 250 V	CONTROL LINE
F2	3 A 250 V	HORN
F3	5 A 250 V	TO GO UNITS
F4	8 A 250 V	SECONDS
F5	8 A 250 V	MINUTES
F6	1/2 A 250 V	CONTROL LINE
F7	3 A 250 V	DOWN, QTR.
F8	5 A 250 V	TO GO TENS
F9	8 A 250 V	HOME SCORE
F10	8 A 250 V	VISITOR SCORE

CONNECTION POINTS

CONNECTION POINT	FUNCTION
T-1	control cable connection
T-2	horn connection
T-3	MOV (surge protection)
T-4	power cable connection
S-9	test jack

ELECTRO-MECH SCOREBOARD CO. FIVE YEAR LIMITED WARRANTY

THE ELECTRICAL COMPONENTS OF ALL ELECTRO-MECH SCOREBOARDS ARE GUARANTEED FOR A PERIOD OF FIVE (5) YEARS FROM THE DATE OF INVOICE AGAINST DEFECTS IN WORKMANSHIP OR MATERIAL AND WILL BE REPLACED OR REPAIRED WITHOUT COST TO THE OWNER PROVIDED THE EQUIPMENT OR PARTS ARE RETURNED POSTAGE-PAID TO THE FACTORY IN WRIGHTSVILLE, GA. SHIPPING BACK TO THE OWNER WILL BE VIA UPS GROUND SERVICE EXCEPT WHEN AIR OR SPECIAL METHOD OF RETURN IS SPECIFIED BY THE OWNER, IN WHICH CASE SHIPPING WILL BE FREIGHT COLLECT.

EXCLUDED FROM THIS WARRANTY ARE LAMPS, FUSES AND SOCKETS.

THIS WARRANTY DOES NOT INCLUDE LABOR CHARGES INCURRED IN THE REMOVAL OF COMPONENT PARTS, SERVICE CALLS, OR DAMAGES RESULTING FROM IMPROPER INSTALLATION, IMPROPER OPERATION, OR PROBLEMS CAUSED BY ANY REPAIR, ALTERATION OR MODIFICATION OF THE SCOREBOARD NOT PERFORMED BY ELECTRO-MECH.

EQUIPMENT WHICH IS SUBJECTED TO ACCIDENT, NEGLIGENCE, ABUSE, MISUSE OR OTHER NATURAL DISASTERS, INCLUDING BUT NOT LIMITED TO FIRE, WIND, LIGHTNING, OR FLOOD, IS NOT COVERED BY THIS GUARANTEE.