

ELECTRO-MECH SCOREBOARD CO.

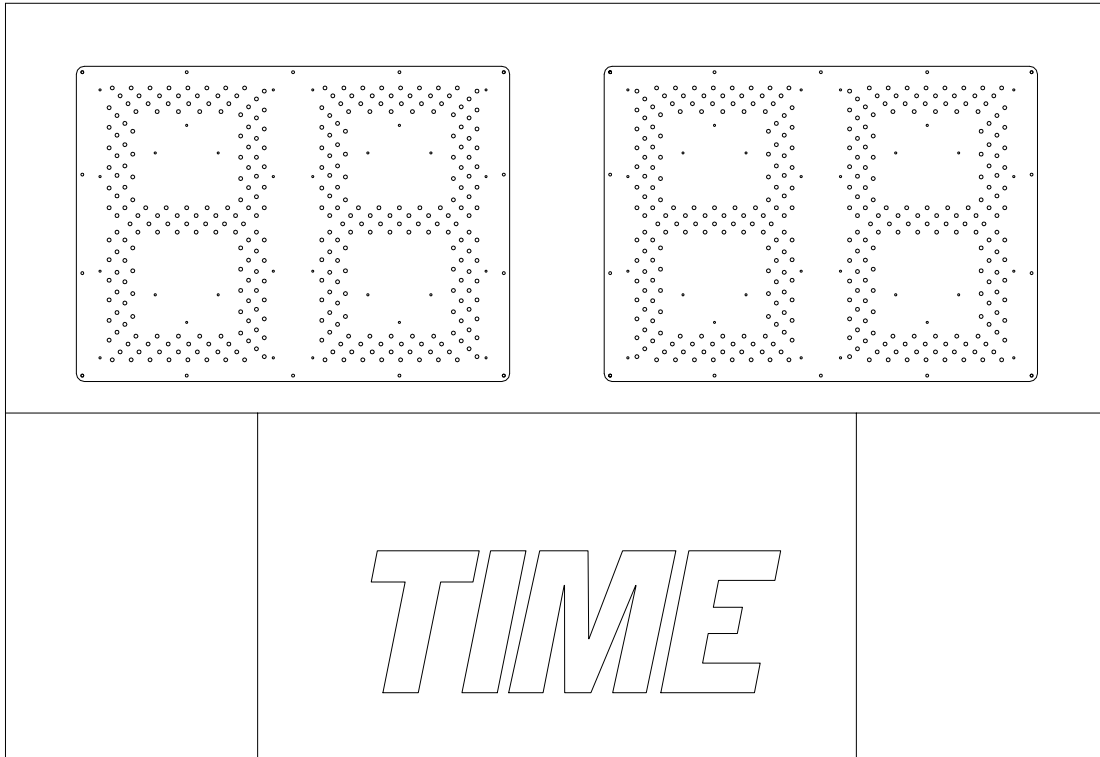

1064 FOUR DIGIT TIMER FOR MM SOFTBALL

OWNER'S HANDBOOK

Thank you for choosing an Electro-Mech Scoreboard for your athletic complex. We are confident that your new softball timer will give many years of reliable service.

TABLE OF CONTENTS

SPECIFICATIONS	3
INSTALLATION.....	4
MECHANICAL INSTALLATION	4
Post Installation.....	4
Mounting The Softball Timer	5
MOUNTING HARDWARE	6
ELECTRICAL INSTALLATION	8
Ground Connection	8
Power Connections.....	9
Horn Installation.....	10
ScoreLink 300.....	11
Control Cable Installation.....	11
Serial Data Output Connections.....	13
Control Console Connections	14
Control Console Safety Warning.....	14
SOFTBALL TIMER OPERATION	15
SOFTBALL TIMER STARTUP	15
GAME TIME OPERATION.....	15
Control Console Key Functions.....	16
SOFTBALL TIMER SHUTDOWN	16
SERVICING THE SOFTBALL TIMER	17
TROUBLESHOOTING TIPS.....	17
COMPONENT REPLACEMENT	18
LED Digits Replacement	18
LX14 Driver Board Replacement.....	20
LED Power Supply Module Replacement	21
WARRANTY	23

SPECIFICATIONS

GENERAL: This ETL listed softball timer includes the softball timer cabinet, mounting hardware, control console, 10 ft. extension cable, and junction box.

DIMENSIONS: 70" L x 48" H x 6" D

WEIGHT: 50 lbs

CONSTRUCTION: The outer frame is made from extruded aluminum. Internal structural parts may be extruded aluminum or formed from aluminum sheet. The face and back are made from aluminum sheet. The face is finished with enamel paint. Black is the standard color. The captions are white exterior grade vinyl.

DISPLAY: The 1064 softball timer displays TIME to 90 minutes.

DIGITS: Red light emitting diodes mounted on printed circuit boards form the digits. The digits are 18" tall.

POWER REQUIREMENTS: **Softball timer** - 120 VAC, 0.4 A, 60 Hz. **Control Console** - 120 VAC, 0.5 A, 60 Hz

SOFTBALL TIMER ELECTRONICS: 100% solid state fully enclosed.

CONTROL CONSOLE: The control console features a microprocessor, 15 key sealed membrane keypad and an attached 6 foot power cord. The console housing consists of ABS plastic base and top pieces with a steel back plate.

CONTROL CABLE: The cable has two 22 AWG stranded copper conductors with semi-rigid PVC insulation. It also has a braided shield and a foil shield. The polyethylene jacket is rated at 300 volts. The cable is direct burial rated and measures approximately 1/4" in diameter. This item is sold separately from the softball timer.

JUNCTION BOX AND EXTENSION CABLE: A 4 1/4" x 2 1/4" x 2" junction box with a 1/4" stereo jack mounted on the face plate is attached to the control cable at the point of operation. A 10 ft. extension cable connects the control console to the junction box.

SCORELINK 300 RF MODEM SYSTEM: This accessory can be used in place of control cable and junction box for this softball timer without internal modifications to the softball timer or the control console. Refer to the SCORELINK 300 RF MODEM SYSTEM OWNER'S HANDBOOK for more information.

WARRANTY: Five year limited warranty.

INSTALLATION

This part of the manual describes the mechanical and electrical installation of the softball timer.

One of the items listed below must be purchased in order to complete the installation:

- Control cable (length dependent upon installation site layout)
- ScoreLink 300 RF Modem System

Items not provided by Electro-Mech Scoreboard Company that are necessary for installation:

- Two posts
- Power cable to connect the softball timer to the power source
- Grounding hardware
- A grounded NEMA 5-15R 120 VAC receptacle for the control console at the scorekeeper's table.

Items not provided that are recommended by Electro-Mech Scoreboard Company for installation:

- A weatherproof power disconnect at the softball timer

Electro-Mech Scoreboard Company performs installations in some areas. In other areas, we can help you contact an independent installer. In areas in which installation service is not available from Electro-Mech Scoreboard Company, we will make every effort to answer your installation questions. Qualified personnel should perform the installation. Consult national and local codes before installation.

MECHANICAL INSTALLATION

The mechanical installation includes installing the posts and mounting the softball timer to the posts.

Post Installation

The softball timer mounts on two posts. Typically installers will use steel pipes or I-beams. In order to reduce the glare from the sun on the front of the softball timer, position the posts so that the front of the softball timer is angled away from the afternoon sun, if possible. The mounting hardware will accommodate posts up to 4.5 inches outer diameter. Sink the posts in reinforced concrete footings. Figure 1 shows the spacing of the posts for a 1064 softball timer. The specifications for the posts and concrete footings are dependent upon the expected local wind and soil conditions, the height of the softball timer from the ground, and the local building codes. Electro-Mech Scoreboard Company assumes no responsibility for installations performed by others.

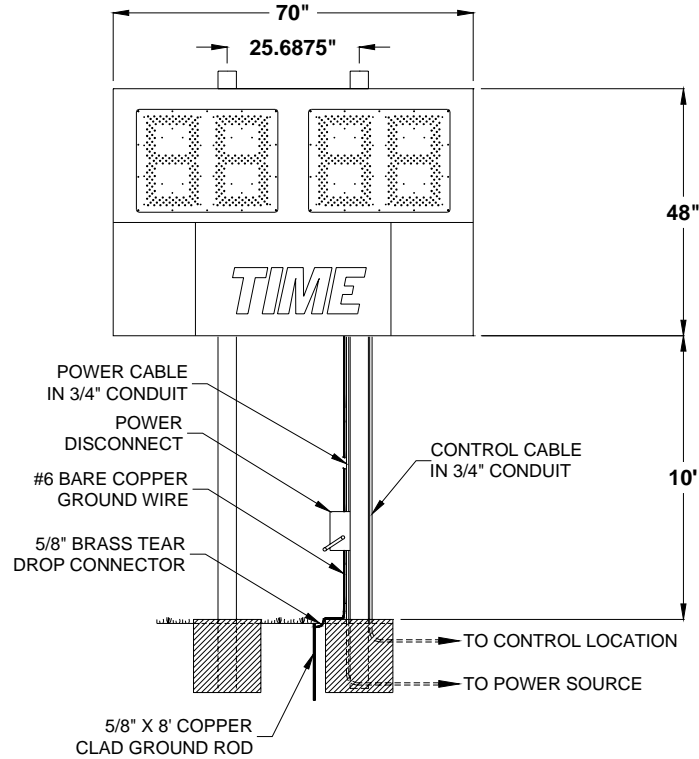

Figure 1 1064 Post Spacing

Mounting The Softball Timer

The softball timer is attached to the posts at four points. Figure 2 shows the location of the mounting points on the rear of the softball timer.

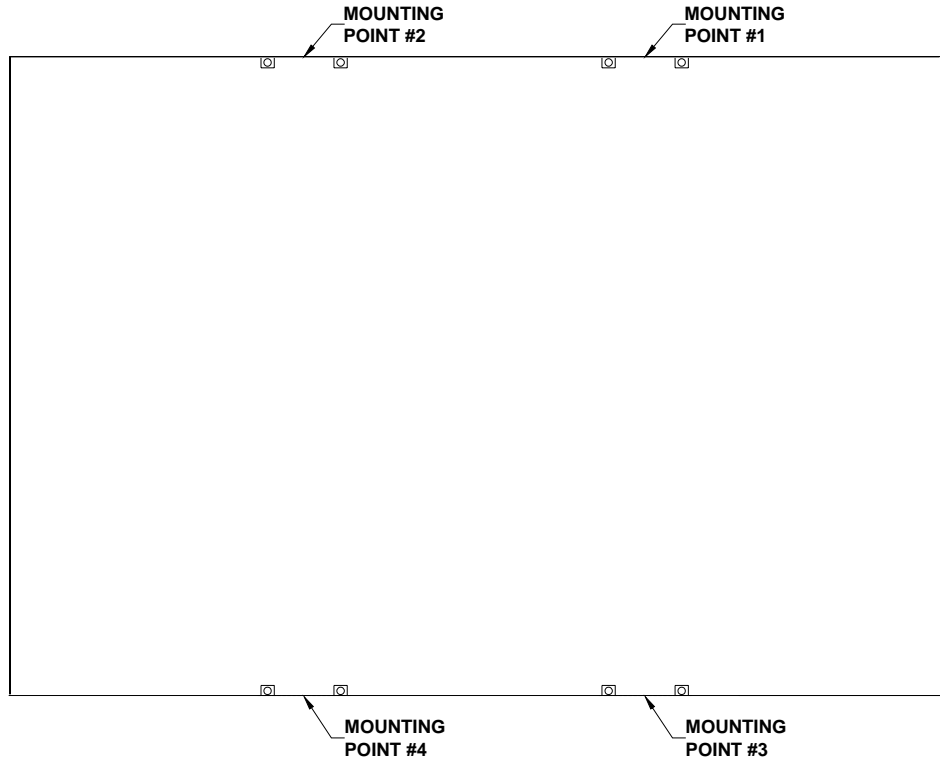

Figure 2 Mounting Points

MOUNTING HARDWARE

Four sets of mounting hardware are provided to attach the softball timer at these points. A single set of mounting hardware for the softball timer consists of a steel angle bracket, two threaded rods, two washers, and two nuts. Figure 3 shows an overhead cross section view and a side cross section view of the softball timer attached to a post at a mounting point. A steel bar is riveted inside the softball timer's aluminum extrusion frame. The bar has two tapped holes. The threaded rods screw into these tapped holes. The washers and nuts are used to clamp the steel angle bracket against the steel post and hold the softball timer in place.

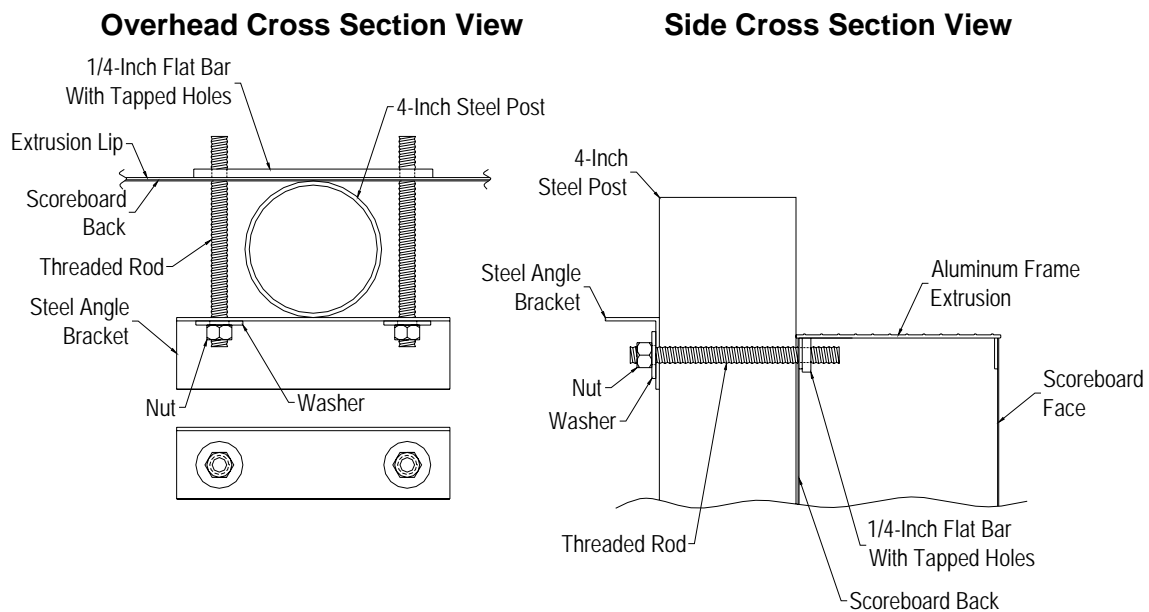

Figure 3 Standard Mounting Method

The following steps describe how to mount the softball timer on the posts:

1. Place the softball timer cabinet against the posts on the ground. Make sure the mounting points are aligned with the posts.
2. Screw the threaded rods into the tapped holes in the softball timer.
3. Place a steel angle bracket over the threaded rods at mounting point #1.
4. Place a washer over each threaded rod.
5. Screw the nuts onto the threaded rods so that the bracket is loosely held in place.
6. Repeat steps 3 - 6 at the other mounting points.
7. Raise the softball timer into place and tighten the nuts to clamp the softball timer in place on the posts.

ELECTRICAL INSTALLATION

We recommend a qualified electrician perform the needed electrical connections to ensure proper operation of the softball timer. These connections include grounding the softball timer, connecting the softball timer to a power source, installing the horn (if purchased), installing the ScoreLink 300 or the control cable, and connecting the control console.

Ground Connection

The National Electrical Code **requires** a softball timer (electric sign) to be grounded. Grounding the softball timer helps the softball timer electronics operate properly and helps minimize damage if it is struck by lightning. Metal posts do **not** provide an adequate ground path. The following steps describe how to connect the softball timer to the power source:

1. Drive one or more 5/8" x 8' copper clad ground rods in the soil near the softball timer.
2. Connect #6 bare copper wire to the ground rods using 5/8" brass tear drop connectors.
3. Remove the front access panel and the dome plugs. Figure 4 shows the location of the access panel. The dome plugs are located on the bottom of the softball timer cabinet below the access panel.

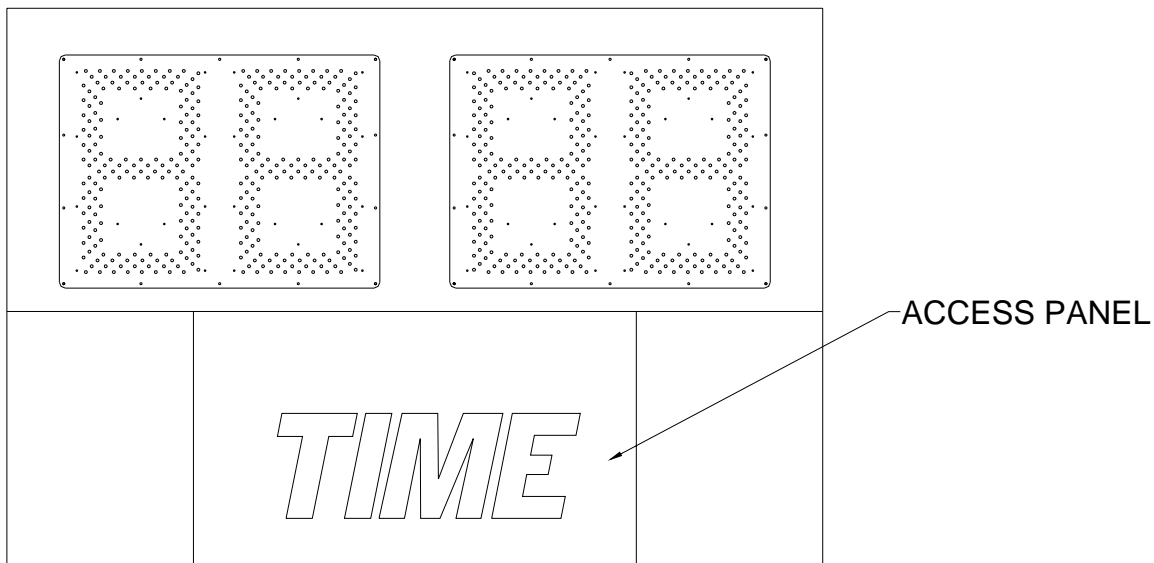

Figure 4 Access Panel

4. Figure 5 shows the view behind the access panel.

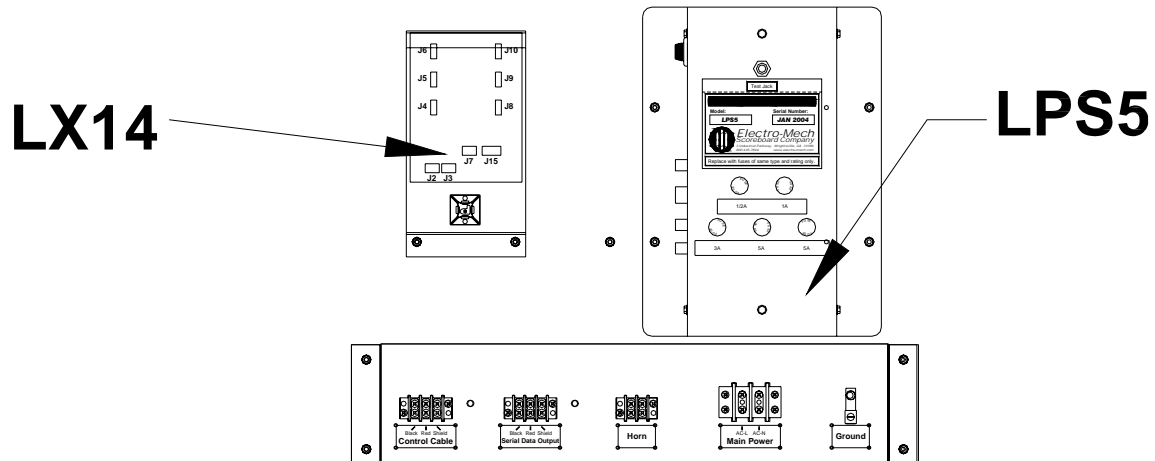

Figure 5 Access Panel Removed

5. Pass the ground conductor through one of the holes bottom of the softball timer cabinet and connect it to the ground lug (**Ground**).

Power Connections

The softball timer requires 120 VAC service at the softball timer to operate properly. **Maximum power consumption of Model 1064: 48 Watts.** Make sure that power cable is rated for this electrical load. Install the power cable in conduit. **Avoid** running the power cable in close proximity to the control cable. The following steps describe how to connect the softball timer to the power source:

1. Feed the power cables through one of the holes in the bottom of the softball timer cabinet.
2. Crimp fork terminals to the power cable wires.
3. Connect the power cable wires to **Main Power** terminal block according to figure 6.

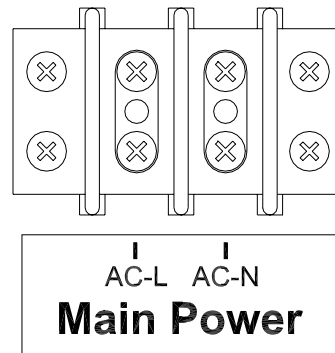

Figure 6 Power Connections

Install a power disconnect that isolates all current carrying conductors on one of the posts below the softball timer (not the ground conductor). If a secondary switch is installed near the scorekeeper's table, it should also isolate these conductors. Place the power disconnect in the **OFF** position between games to help protect the softball timer from lightning damage. A power disconnect on the softball timer post also provides a convenient way of turning the softball timer off during maintenance or repairs.

Horn Installation

The items provided to install the horn are the horn, the mounting bolt, and the mounting bracket. Items which are not provided but are necessary for proper installation are $\frac{3}{4}$ " conduit, a two $\frac{3}{4}$ " male conduit connectors, a $\frac{3}{4}$ " straight male conduit connector, two wires, two forked crimp terminals, and two butt splice connectors. The electrical requirements for the horn are 0.35 A 120 VAC. The horn is mounted to the right side of the softball timer. If a horn was purchased with the softball timer, a tapped hole is provided to fasten the horn to the softball timer. The mounting bolt is screwed into the tapped hole at the factory. The following steps describe the assembly and mounting of the horn:

1. Cut a piece of $\frac{3}{4}$ " conduit of sufficient length to reach from the horn mounting point to one of holes in the bottom of the scoreboard.
2. Attach the conduit connectors to the ends of the conduit.
3. Cut two pieces of wire of approximately 4 feet longer than the conduit.
4. Push the wires through the conduit.
5. Peel the tape off the horn projector.
6. Remove the plastic bag from inside the horn projector.
7. Remove the four screws that fasten the horn and horn projector to the weatherproof back box.
8. Feed the two wire leads that are attached to the rear side of the horn through one of the threaded holes on the side of the weatherproof back box. Two of the holes will accept a $\frac{3}{4}$ " conduit connector.
9. Plug the other two threaded holes with the plugs from the plastic bag.
10. Splice the horn wire leads to the two wires that run through the conduit with the butt splice connectors.
11. Screw the conduit connector into the threaded hole on the weatherproof back box.

12. Attach the horn and horn projector to the weatherproof back box using the four screws.
13. Fasten the horn assembly to the softball timer using the mounting bolt from the softball timer.
14. Crimp forked terminals on the ends of the two wires that protrude out of the other end of the conduit.
15. Pass the wires through one of holes in the bottom of the softball timer cabinet.
16. Fasten the conduit connector to the plate and connect the wires to the **Horn** terminal block on the junction chassis. Connect the AC-L wire to the left terminal and the AC-N wire to the right terminal.

ScoreLink 300

The ScoreLink 300 RF MODEM SYSTEM is designed to eliminate the control cable between the softball timer and the control console on Electro-Mech Scoreboard MM and MP series scoreboards as well as all LED scoreboards. Customers who are adding a model 1064 softball timer to a field with a compatible softball / baseball scoreboard that already uses a ScoreLink 300 must install a ScoreLink 300 receiver at the softball timer on the same channel as the existing system. If you have purchased this accessory, disregard the section of this manual titled **Control Cable Installation**. Refer to the ScoreLink 300 RF MODEM SYSTEM OWNER'S HANDBOOK for installation instructions.

Control Cable Installation

The control cable connects the softball timer to the control console. Customers who are adding a model 1064 softball timer to a field with a compatible softball / baseball scoreboard must either disconnect the control cable from the softball / baseball scoreboard and either connect it to the model 1064 softball timer or install new control cable from the control console to the model 1064 softball timer. Install the control cable in conduit. If the cable is ever damaged, it is easier and less expensive to replace a cable in conduit. A small junction box with a ¼" stereo jack mounted on the face plate is attached to the control cable at the point of operation of the softball timer. This junction box should be securely mounted in a clean, dry area within ten feet of the rear of the control console. Most customers order the control cable with the junction box attached. Some customers prefer to attach the junction box after the cable is installed. Those customers must solder the control cable to the ¼" stereo jack. Figure 7 shows the control cable wire connection points on the rear of the ¼" stereo jack.

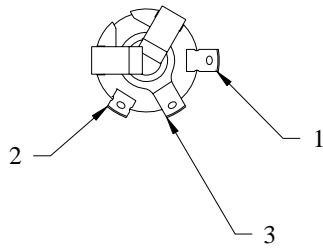

PIN 1 - BLACK WIRE
 PIN 2 - RED WIRE
 PIN 3 - SHIELD WIRE

Figure 7 1/4" Stereo Jack Wiring Diagram

The following steps describe how to connect the control cable to the softball timer:

1. Feed the control cable through one of the holes in the bottom of the softball timer cabinet.
2. Crimp fork terminals to the control cable wires and the shield.
3. Connect the control cable to **Control Cable** terminal block according to figure 8.

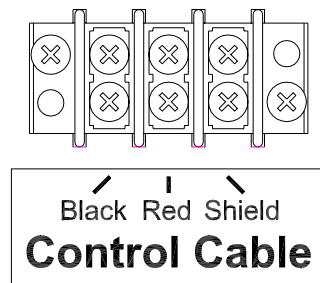

Figure 8 Control Cable Wiring Diagram

Serial Data Output Connections

Customers who are adding a model 1064 softball timer to a field with a compatible softball / baseball scoreboard must install a cable to send data from the model 1064 softball timer to the softball / baseball scoreboard (unless a ScoreLink 300 system is installed). Do not splice the existing control cable that is connected to the softball / baseball scoreboard in order to send data to the model 1064 softball timer. Do not connect two control cables to the junction box ¼" stereo jack. Do not connect a cable from the softball / baseball scoreboard **Control Cable** terminal block to the model 1064 softball timer **Control Cable** terminal block. The following steps describe how to transmit data from a model 1064 softball timer to the softball / baseball scoreboard:

1. Feed cable (same type of cable specified for control cable on page 3) through a hole in the bottom of the model 1064 softball timer.
2. Crimp fork terminals to the cable wires and the shield.
3. Connect the cable to the terminal block labeled **Serial Data Output** according to figure 9.

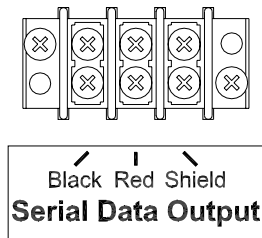

Figure 9 Serial Data Output Wiring Diagram

4. Remove the softball / baseball scoreboard rear access panel.
5. Feed the cable through a hole in the plate below the access panel.
6. Crimp fork terminals to the cable wires and the shield.
7. Connect the cable to the terminal block labeled **Control Cable** on the softball / baseball scoreboard junction chassis according to figure 10.

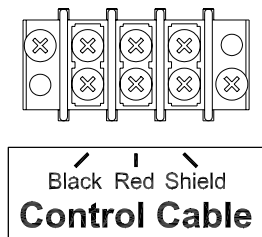

Figure 10 Control Cable Wiring Diagram

8. Reinstall the access panels.

Control Console Connections

The 10 ft. extension cable has two molded ¼” stereo plugs attached to it. It is used to connect the control console to the junction box. The following steps describe how to connect the control console:

1. Plug one end of the extension cable into ¼” stereo jack on the junction box or the ScoreLink 300 Transmitter, if purchased.
2. Plug the other end into the ¼” stereo jack mounted on the control console back plate.
3. Plug the control console power cord into a grounded NEMA 5-15R 120 VAC receptacle.

Control Console Safety Warning

This product is equipped with a 3-wire grounding type plug, a plug having a third (grounding) pin. This plug will only fit into a grounding-type power outlet. This is a safety feature. If you are unable to insert the plug into the outlet, contact a qualified electrician to replace your obsolete outlet. Do not defeat the purpose of the grounding-type plug.

SOFTBALL TIMER OPERATION

SOFTBALL TIMER STARTUP

1. Place the power disconnect for the softball timer in the **ON** position.
2. Plug one end of the extension cable into ¼" stereo jack on the junction box or the ScoreLink 300 Transmitter, if purchased.
3. Plug the other end into the ¼" stereo jack mounted on the control console back plate.
4. Plug the control console power cord into a grounded NEMA 5-15R 120 VAC receptacle.
5. If a ScoreLink 300 RF MODEM SYSTEM is installed with this softball timer, plug the wall mount DC power supply into a grounded NEMA 5-15R 120 VAC receptacle and the male plug on the end of the attached cable into the Power jack on the Transmitter.

GAME TIME OPERATION

This softball timer is operated with a 15-key control console. Customers with existing compatible softball / baseball scoreboards can use their control console to operate a model 1064 softball timer. Figure 11 shows the keypad layout on the control console.

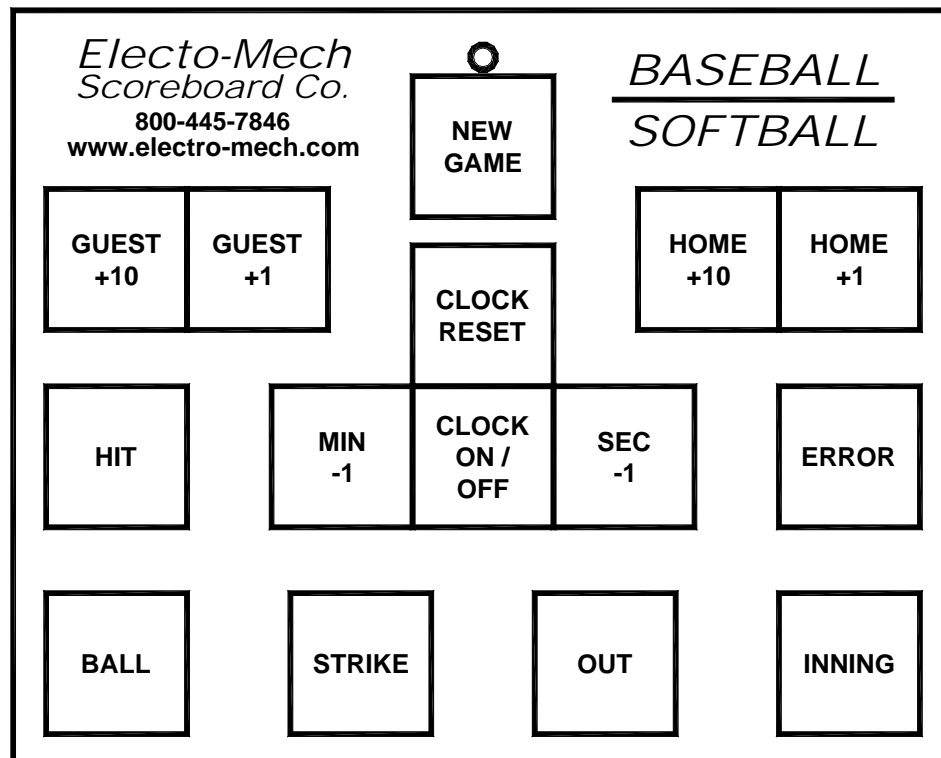

Figure 11 Keypad Layout

The softball timer will display:
CLOCK – 15:00

Control Console Key Functions

1. **NEW GAME** – This key can be used to reset all softball timer functions. Press **NEW GAME** and, within two seconds, press **CLOCK RESET**. Guest and Home scores, and will be set to zero. The **BALLS, STRIKES, and OUTS** will be blanked. The clock will display 30 minutes. The colon indicator will be off.
2. **CLOCK RESET** – This key is used increment the clock in 30 minute intervals. This will allow the clock to be set to 30, 60, or 90 minutes.
3. **CLOCK ON / OFF** – This key toggles the clock on and off. The clock displays minutes until the last minute, when it displays seconds. The colon light to the left of the clock digits on the softball timer will blink when the clock is on. The horn will sound when the clock reaches 0 seconds.
4. **DEC. MIN.** – This key decreases the clock by one minute.
5. **DEC. SEC.** – This key decreases the clock by one second.

The other keys are not used with the model 1064, but may be used for a softball scoreboard.

You should reset the softball timer each time that it is turned on. Test out all the functions to ensure that the softball timer is operating properly.

SOFTBALL TIMER SHUTDOWN

1. Place the power disconnect for the softball timer in the **OFF** position.
2. Unplug the control console power cord.
3. Unplug the extension cable.
4. If a ScoreLink 300 RF MODEM SYSTEM is installed with this softball timer, unplug the Transmitter's wall mount power supply.
5. Store the control console and ScoreLink 300 Transmitter in a dry location. These units are not waterproof.

Proper softball timer shutdown will help protect the softball timer and control console from power surges and lightning strikes.

SERVICING THE SOFTBALL TIMER

While your softball timer was designed for years of trouble-free operation, some problems may occasionally occur. Electro-Mech Scoreboard Company offers onsite service in some areas. In other areas, we can help you contact an independent service technician. In areas in which service is not available from Electro-Mech Scoreboard Company, we will make every effort to answer your questions. Our trained personnel at Electro-Mech Scoreboard Company are ready to answer your questions from Monday to Friday during the hours of 8 AM to 5 PM Eastern Standard Time. Be sure to know your softball timer model number when calling. Softball timer replacement parts are always available. Damaged parts can usually be repaired at a significant cost savings. Our convenient toll free number is listed at the bottom of every page in this manual.

TROUBLESHOOTING TIPS

Before calling Electro-Mech Scoreboard Co. for customer support of a softball timer problem, it is helpful to make note of all the symptoms. If the softball timer does not turn on digits, please check the following items:

1. Make sure the control console power cord and the extension cable are plugged in.
2. Verify that the red LED above the NEW GAME key on the control console keypad is lit.
3. Check the circuit breaker that supplies power to the softball timer.
4. Remove the softball timer rear access panel and check the voltages present at the **Main Power** terminal block.
5. Check the fuses on the LPS5 Power Supply Module.
6. Make sure all wire and ribbon cable connections are plugged in securely.
7. Take the control console and the 10 ft. extension cable to the softball timer.

Temporarily disconnect the control cable from the **Control Cable** terminal block and plug the 10 ft. extension cable into the test jack on the LX14 LED driver board. Plug the control console power cord into the 120 VAC receptacle on the left side of the LPS5 Power Supply Module. If the LEDs are now illuminated and the softball timer reacts to control console entries, there may be a problem with the control cable or the ScoreLink 300 modem, if purchased.

If the softball timer turns on LEDs, but does not operate normally, make note of which functions are affected. If some LEDs either never turn on or always stay on, make note of their specific locations on the softball timer. Refer to the COMPONENT REPLACEMENT section of this manual before changing parts.

COMPONENT REPLACEMENT

LED digits are serviced from the front of the softball timer.

LED Digits Replacement

The LEDs that form digits and indicators are soldered on circuit boards mounted behind the scoreboard face. Do not attempt to replace individual LEDs. In case of a malfunction, the entire LED circuit board must be removed. **To avoid damage to the LED driver module, always turn off the power to the softball timer when removing or replacing LED digits.** Figure 12 shows the components of a LED digit assembly. LED indicator assemblies are similar in construction.

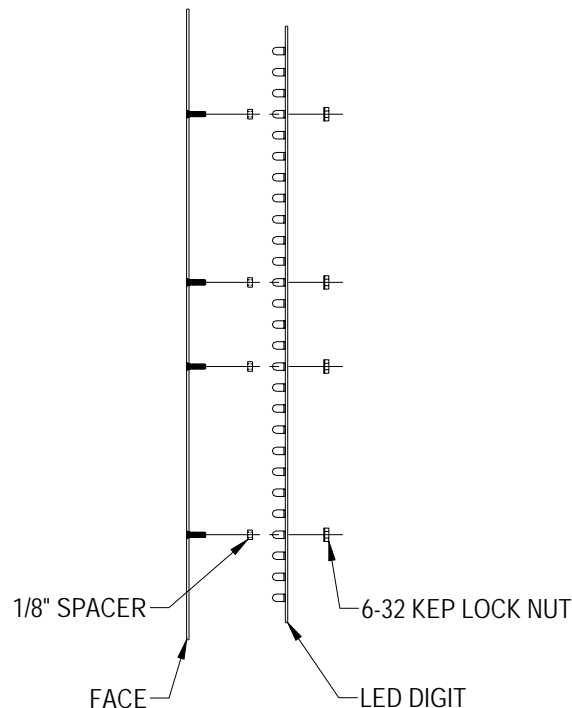
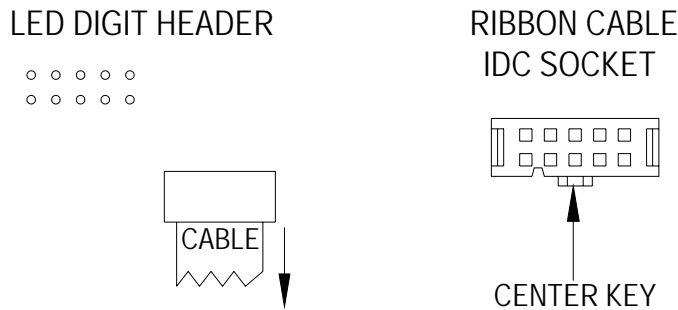

Figure 12 LED Digit Assembly

1. Remove the sheet metal screws that fasten the upper face panel of the softball timer. **Caution: Support the panel with before removing the last screw. The ribbon cable that connects to the rear of the circuit board is not designed to support the weight of the assembly.**
2. Disconnect the ribbon cable from the rear of the circuit board. **Caution: Do not let the cable hang outside of the softball timer. It is easily cut by sharp metal edges. Damage to the ribbon cable may create short circuit paths that will damage the LED driver module.**
3. Place the assembly on a flat surface and remove the 6-32 kep lock nuts that hold the circuit board in place.
4. Remove the circuit board.
5. Align the mounting holes in the circuit board with the threaded studs on the face panel and install the replacement digit on the face panel.

- Plug the ribbon cable onto the header on the back of the circuit board. Refer to figure 13 in order to plug the ribbon cable IDC connector onto the circuit board in the proper orientation.



CENTER KEY ON RIBBON CABLE IDC SOCKET
MUST POINT IN THE SAME DIRECTION AS THE
ARROW ON THE REAR OF THE LED DIGIT.

Figure 13 LED Digit Ribbon Cable Connection Diagram

All other components are located behind the access panel. Figure 14 shows the view behind the access panel.

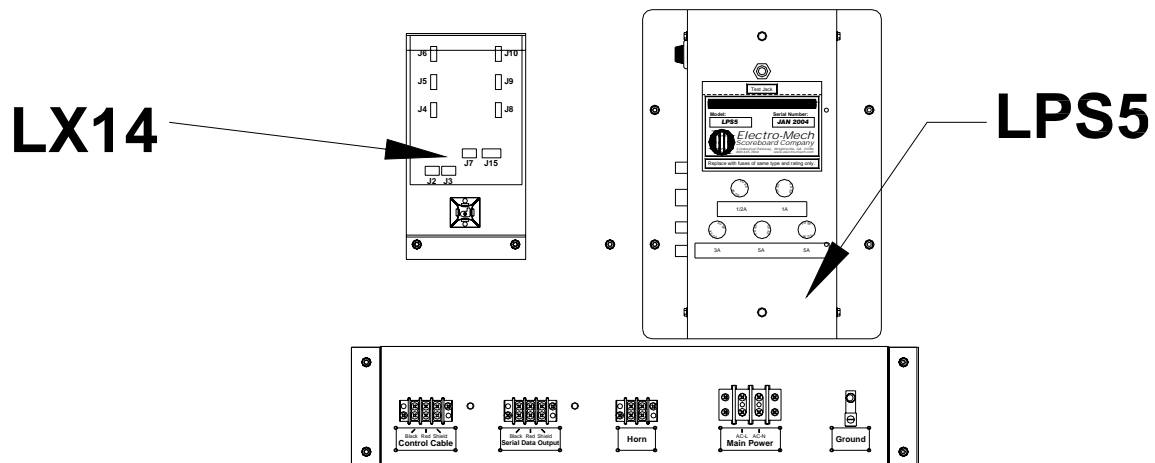

Figure 14 Access Panel Components

LX14 LED DRIVER BOARD FUNCTIONS

DRIVER MODULE JACK	FUNCTION
J7	DC POWER INPUT
J2	SERIAL DATA INPUT
J3	SERIAL DATA OUTPUT
J4	SECONDS UNITS DIGIT
J5	SECONDS TENS DIGIT
J6	MINUTES UNITS DIGIT
J8	NOT USED
J9	MINUTES TENS DIGIT
J10	NOT USED
J15	HORN RELAY CONTROL

LX14 Driver Board Replacement

Electrical connections to the LX14 LED DRIVER BOARD are made with ribbon cable polarized IDC sockets and locking ramp crimp terminal housings that mate with jacks on the circuit board. The circuit board is secured inside the softball timer on a metal bracket with two hex nuts.

1. Unplug the electrical connections from the circuit board.
2. Remove the two hex nuts.
3. Remove the circuit board from the softball timer.
4. Insert the replacement circuit board on the metal bracket in the softball timer.
5. Secure the circuit board with the two hex nuts.
6. Insert the plugs into the jacks on the circuit board.

To avoid damage to the circuit board, always turn off the power to the softball timer when removing or replacing it.

LPS5 LED POWER SUPPLY MODULE FUNCTIONS

Figure 15 shows the location of the fuses in the LPS5 LED Power Supply Module. The table following the figure lists the fuse ratings, functions, and part numbers.

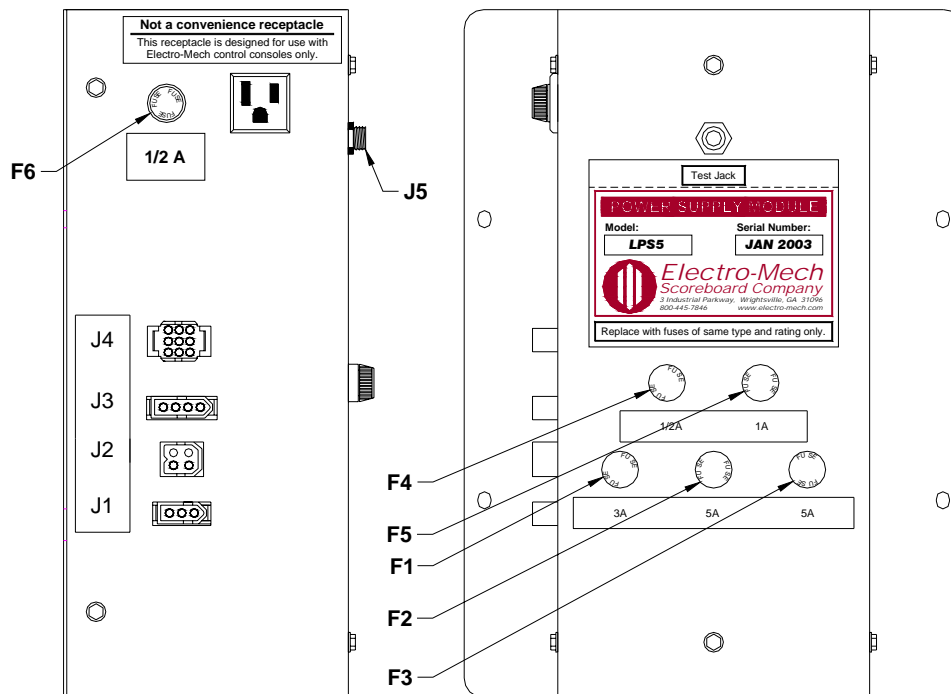

Figure 15 LPS5 Fuse Locations

LPS5 FUSES

FUSE	RATING	FUNCTION	BUSSMAN PART #
F1	3A 250V	TRANSFORMER PRIMARY	AGC-3
F2	5A 250V	DRIVER MODULE DC POWER INPUT #1	AGC-5
F3	5A 250V	NOT USED	AGC-5
F4	½A 250V	SERIAL DATA ISOLATION RELAY	AGC-1/2
F5	1A 250V	HORN	AGC-1
F6	½A 250V	120 VAC ELECTRICAL RECEPTACLE	AGC-1/2

Note: Other manufacturer's fuses may be substituted for the Bussmann fuses.

LED Power Supply Module Replacement

Electrical connections to the LED POWER SUPPLY MODULE LPS5 are made with four keyed plugs that mate with jacks on the left side of the module. The module is secured inside the softball timer with four machine screws.

1. Disconnect the plugs from the jacks on the side of the module.
2. Remove the four screws.
3. Remove the module from the softball timer.
4. Insert the replacement module in the softball timer.
5. Secure the module with the four screws.
6. Insert the plugs into the jacks on the side of the module.

To avoid damage to the module, always turn off the power to the softball timer when removing or replacing it.

ELECTRO-MECH SCOREBOARD CO. FIVE YEAR LIMITED WARRANTY

THE ELECTRICAL COMPONENTS OF ALL ELECTRO-MECH SCOREBOARDS ARE GUARANTEED FOR A PERIOD OF FIVE (5) YEARS FROM THE DATE OF INVOICE AGAINST DEFECTS IN WORKMANSHIP OR MATERIAL AND WILL BE REPLACED OR REPAIRED WITHOUT COST TO THE OWNER PROVIDED THE EQUIPMENT OR PARTS ARE RETURNED POSTAGE-PAID TO THE FACTORY IN WRIGHTSVILLE, GA. SHIPPING BACK TO THE OWNER WILL BE VIA UPS GROUND SERVICE EXCEPT WHEN AIR OR SPECIAL METHOD OF RETURN IS SPECIFIED BY THE OWNER, IN WHICH CASE SHIPPING WILL BE FREIGHT COLLECT.

EXCLUDED FROM THIS WARRANTY ARE LAMPS, FUSES AND SOCKETS.

THIS WARRANTY DOES NOT INCLUDE LABOR CHARGES INCURRED IN THE REMOVAL OF COMPONENT PARTS, SERVICE CALLS, OR DAMAGES RESULTING FROM IMPROPER INSTALLATION, IMPROPER OPERATION, OR PROBLEMS CAUSED BY ANY REPAIR, ALTERATION OR MODIFICATION OF THE SCOREBOARD NOT PERFORMED BY ELECTRO-MECH.

EQUIPMENT WHICH IS SUBJECTED TO ACCIDENT, NEGLIGENCE, ABUSE, MISUSE OR OTHER NATURAL DISASTERS, INCLUDING BUT NOT LIMITED TO FIRE, WIND, LIGHTNING, OR FLOOD, IS NOT COVERED BY THIS GUARANTEE.