

ELECTRO-MECH SCOREBOARD CO.

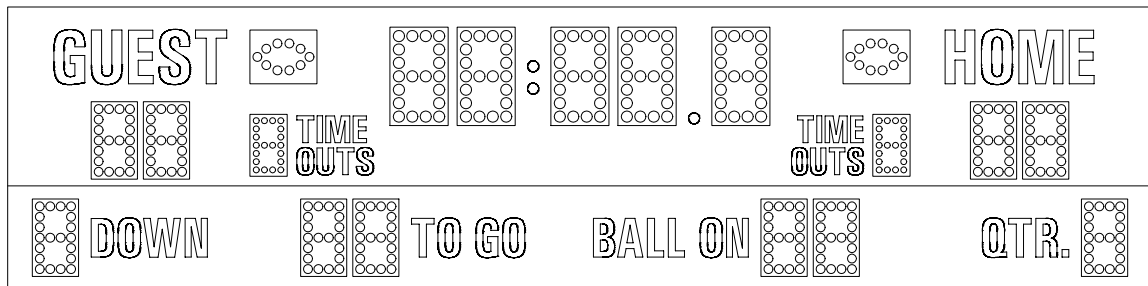

MP-374-TK FOOTBALL SCOREBOARD

OWNER'S HANDBOOK

Thank you for choosing an Electro-Mech Scoreboard for your athletic complex. We are confident that your new scoreboard will give many years of reliable service.

TABLE OF CONTENTS

MP-374-TK FOOTBALL SCOREBOARD

SPECIFICATIONS	3
SCOREBOARD INSTALLATION	4
MECHANICAL INSTALLATION	4
Post Installation.....	4
Mounting The Scoreboard	6
Mounting The Optional Top Sponsor Panel	8
ELECTRICAL INSTALLATION.....	8
Ground Connection	8
Horn Installation.....	9
Power Connection to Scoreboard.....	13
ScoreLink 300.....	16
Serial Data Output Connections.....	16
Control Cable Installation.....	18
Control Console Connections	19
Control Console Safety Warning.....	19
SCOREBOARD OPERATION.....	19
SCOREBOARD STARTUP	19
GAME TIME OPERATION.....	20
Control Console Key Functions.....	21
Hand Held Clock Control Unit Operation	25
SCOREBOARD SHUTDOWN.....	25
SERVICING THE SCOREBOARD	26
TROUBLESHOOTING TIPS.....	26
COMPONENT REPLACEMENT	26
LAMP REPLACEMENT	26
PLUG IN MODULE REPLACEMENT	29
WARRANTY	30

MP-374-TK FOOTBALL SCOREBOARD SPECIFICATIONS

GENERAL: This ETL listed scoreboard includes the scoreboard cabinet, a horn, mounting hardware, control console, 10 ft. extension cable, and junction box.

DIMENSIONS: MP-374-TK: 32' L x 94.75" H x 6" D? (the top section measures 32' L x 5' H x 6" D, the bottom section measures 32' L x 34.75" H x 6" D

WEIGHT: MP-374-TK: 835 lbs (The top section weighs 325 lbs, the bottom section weighs 510 lbs)

SCOREBOARD CONSTRUCTION: The scoreboard consists of two sections. The outer frame is made from extruded aluminum. Internal structural parts may be extruded aluminum or formed from aluminum sheet. The face and back are made from aluminum sheet. The face and expanded metal screens are finished with enamel paint. Black is the standard color. The captions are white exterior grade vinyl.

DISPLAY: The MP-374-TK football scoreboard displays HOME and GUEST scores, BALL ON, and YDS. TO GO to 99, TIME to 99 minutes and 59 seconds (99:59), DOWN, QTR, and TIME-OUTS to 4, and Possession indicators. The TIME includes a fifth digit that displays 1/10th seconds at all times.

LAMP BANKS: A 4 x 7 matrix of lamps forms each digit. The clock digits are 30" tall. The HOME and GUEST score, BALL ON, TO GO, DOWN, and QTR digits are 24" tall. The TIME OUTS digits are 18" tall. Each possession indicator is formed in the shape of a football. The scoreboard uses 15 watt 120 VAC frosted medium based appliance lamps (also known as 15A15IF lamps). Recessed aluminum reflectors provide a crisp separation between each lamp. Expanded metal screens protect the lamps.

POWER REQUIREMENTS: Scoreboard - 120 VAC, 45 A, 60 Hz, 5400 watts, (60 A service recommended).
Control Console - 120 VAC, 0.5 A, 60 Hz

SCOREBOARD ELECTRONICS: 100% solid state fully enclosed within 4 plug in modules.

CONTROL CONSOLE: The control console features a microprocessor, 37 key sealed membrane keypad, a LCD display, an attached 6 foot power cord, and either a lithium cell battery or two super capacitors to retain game information. The console housing consists of ABS plastic base and top pieces with a steel back plate.

CONTROL CABLE: The cable has two 22 AWG stranded copper conductors with semi-rigid PVC insulation. It also has a braided shield and a foil shield. The polyethylene jacket is rated at 300 volts. The cable is direct burial rated and measures approximately 1/4" in diameter. This item is sold separately from the scoreboard.

JUNCTION BOX AND EXTENSION CABLE: A 4 1/4" x 2 1/4" x 2" junction box with a 1/4" stereo jack mounted on the face plate is attached to the control cable at the point of operation. A 10 ft. extension cable connects the control console to the junction box.

SCORELINK 300 RF MODEM SYSTEM: This accessory can be used in place of control cable and junction box for this scoreboard without internal modifications to the scoreboard or the control console. Refer to the SCORELINK 300 RF MODEM SYSTEM OWNER'S HANDBOOK for more information.

WARRANTY: Five year limited warranty.

SCOREBOARD INSTALLATION

This part of the manual describes the mechanical and electrical installation of the scoreboard.

One of the items listed below must be purchased in order to complete the installation:

- Control cable (length dependent upon installation site layout)
- ScoreLink 300 RF Modem System

Items not provided by Electro-Mech Scoreboard Company that are necessary for installation:

- Four posts
- Power cable to connect the scoreboard to the power source
- Grounding hardware
- A grounded NEMA 5-15R 120 VAC receptacle for the control console at the scorekeeper's table.

Items not provided that are recommended by Electro-Mech Scoreboard Company for installation:

- A weatherproof power disconnect at the scoreboard
- A weatherproof NEMA 5-15R 120 VAC convenience receptacle at the scoreboard.

Electro-Mech Scoreboard Company performs installations in some areas. In other areas, we can help you contact an independent installer. In areas in which installation service is not available from Electro-Mech Scoreboard Company, we will make every effort to answer your installation questions. Qualified personnel should perform the scoreboard installation. Consult national and local codes before installation.

MECHANICAL INSTALLATION

The mechanical installation includes installing the posts and mounting the scoreboard and the optional side or top sponsor panels (if purchased) to the posts.

Post Installation

The scoreboard mounts on four posts. Typically installers will use steel pipes or I-beams. In order to reduce the glare from the sun on the front of the scoreboard, position the posts so that the front of the scoreboard is angled away from the afternoon sun, if possible. The mounting hardware will accommodate posts up to 7 inches outer diameter. Sink the posts in reinforced concrete footings. Figure 1 shows the spacing of the posts for a MP-374-TK scoreboard. The specifications for the posts and concrete footings are dependent upon the expected local wind and soil conditions, the height of the scoreboard from the ground, and the local building codes. Electro-Mech Scoreboard Company assumes no responsibility for the installation of scoreboards by others.

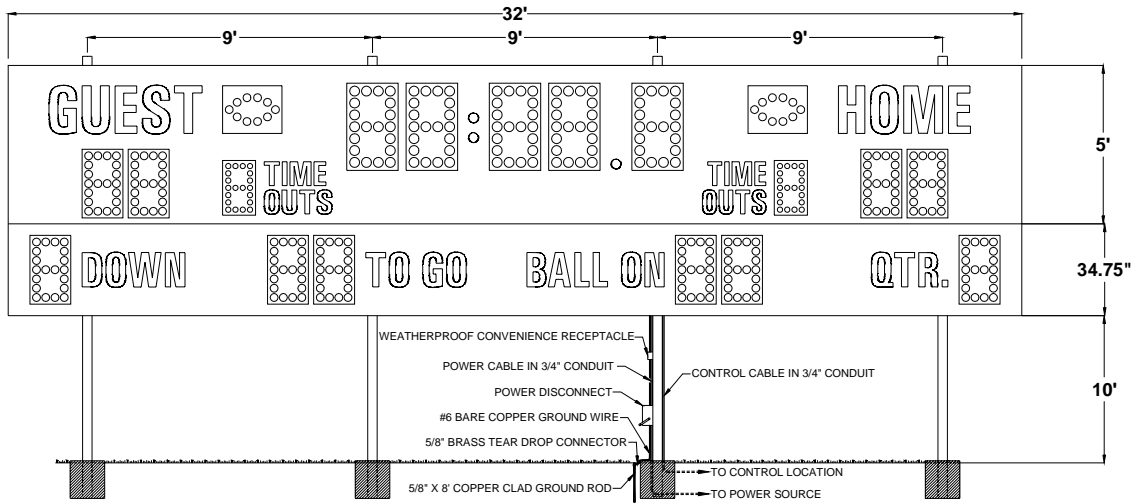

Figure 1 MP-374-TK Post Spacing

Figure 2 shows the spacing of the posts for a MP-374-TK with a top sponsor panel. This panel is a separate unit that mounts on the same posts as the scoreboard.

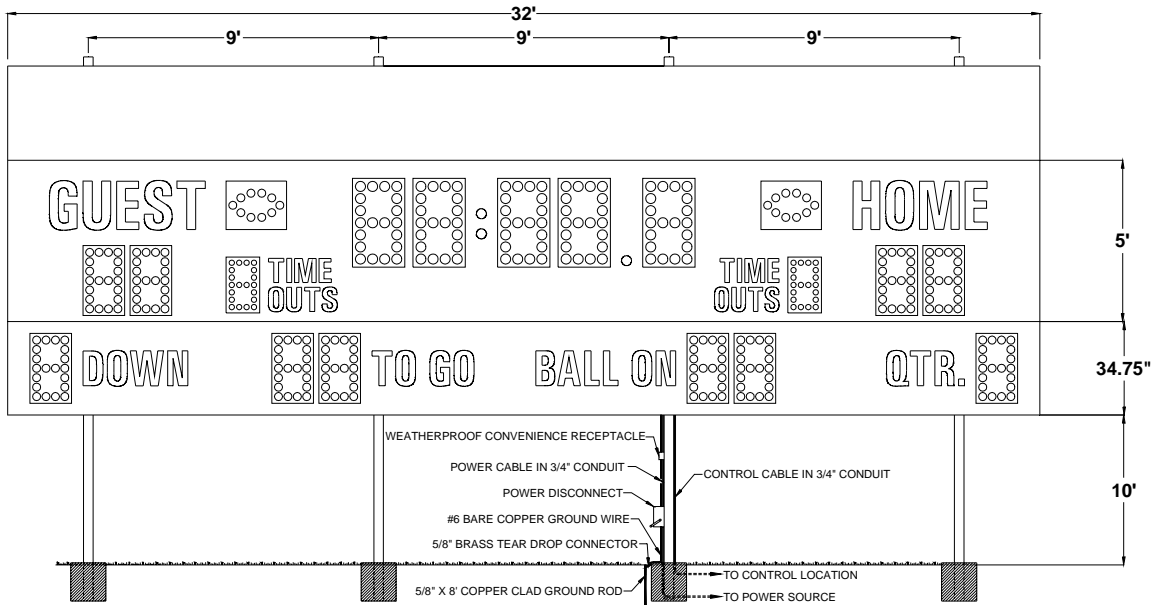

Figure 2 MP-374-TK with Top Sponsor Panel Post Spacing

Mounting The Scoreboard

Each section of the scoreboard is attached to the posts at four points. Figure 3 shows the location of the mounting points on the rear of the scoreboard.

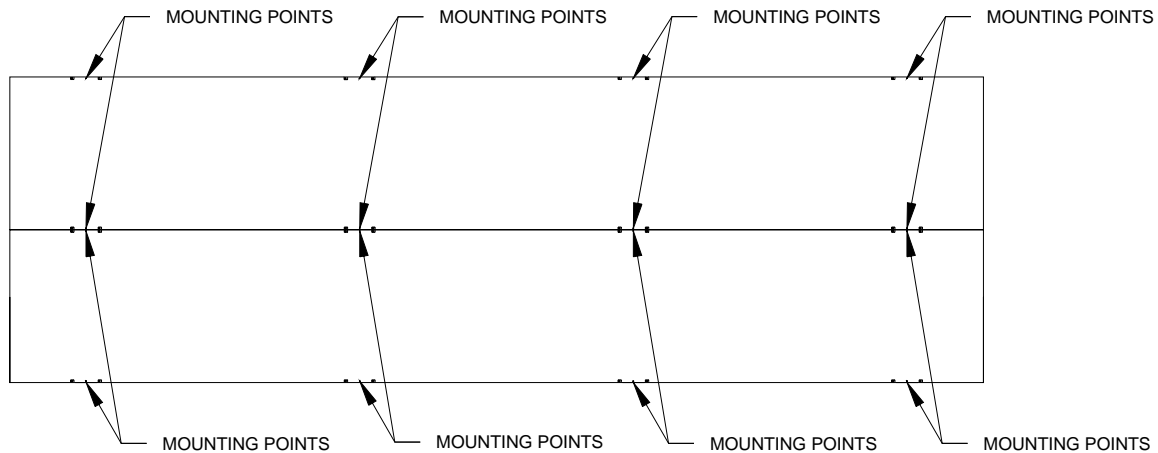

Figure 3 Mounting Points

Sixteen sets of mounting hardware are provided to attach the scoreboard at these points. Additional hardware sets are provided to attach the optional sponsor panels, if ordered. A single set of mounting hardware for the scoreboard consists of an aluminum angle bracket, two threaded rods, two washers, and two nuts. A single set of mounting hardware for an optional top sponsor panel consists of an aluminum angle bracket, two threaded rods, four washers, and four nuts. Figure 4 shows an overhead cross section view and a side cross section view of the scoreboard attached to a post at a mounting point. A steel bar is riveted inside the scoreboard's aluminum extrusion frame. The bar has two tapped holes. The threaded rods screw into these tapped holes. The washers and nuts are used to clamp the aluminum angle bracket against the steel post and hold the scoreboard in place.

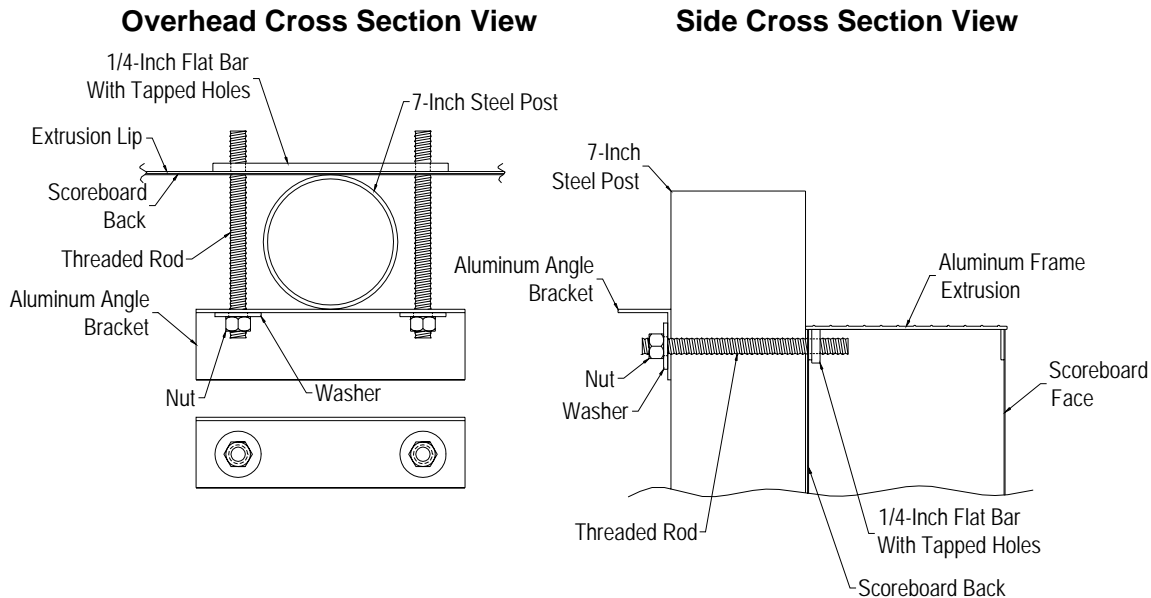

Figure 4 Standard Mounting Method

The following steps describe how to mount the scoreboard on the posts:

1. Place the lower section of the scoreboard against the posts on the ground. Make sure the mounting points are aligned with the posts.
2. If the eyebolts are installed in the upper section of the scoreboard, unscrew them and screw them into the lower section of the scoreboard.
3. Screw the threaded rods into the tapped holes in the scoreboard.
4. Place an aluminum angle bracket over the threaded rods at a mounting point.
5. Place a washer over each threaded rod.
6. Screw the nuts onto the threaded rods so that the bracket is **loosely** held in place.
7. Repeat steps 4 -6 at the other mounting points.
8. Raise the section into place and tighten the nuts to clamp it in place on the posts.
9. Unscrew the eyebolts from the lower section of the scoreboard and screw them into the upper section of the scoreboard.
10. Place the upper section of the scoreboard against the posts a few inches above the lower scoreboard section. Make sure the mounting points are aligned with the posts.
11. There is a cable with a 15 pin plug which is accessible through an opening in the top of the lower section frame. Plug this cable into the 15 pin socket which is accessible through an opening in the bottom of the top section frame.
12. Place the upper section of the scoreboard on top of the lower section.
13. Attach the mounting hardware by the same method as the lower section.
14. Tighten the nuts to clamp it in place on the posts.

Mounting The Optional Top Sponsor Panel

Additional hardware sets are provided to attach the optional top sponsor panels, if purchased. The following steps describe how to mount the top sponsor panel on the posts:

1. Raise the top sponsor panel in place above the scoreboard. Make sure the mounting points are aligned with the posts.
2. Place the threaded rods through the mounting holes in the top sponsor panel at one mounting point.
3. Place a washer over each threaded rod inside the frame of the top sponsor panel, and screw a nut onto each threaded rod behind the washers inside the frame of the top sponsor panel.
4. Place an aluminum angle bracket over the threaded rods at a mounting point.
5. Place a washer over each threaded rod.
6. Screw a nut onto each threaded rod so that the bracket is loosely held in place.
7. Repeat steps 2 - 6 at the other mounting points.
8. Tighten the nuts to clamp it in place on the posts.

ELECTRICAL INSTALLATION

We recommend a qualified electrician perform the needed electrical connections to ensure proper operation of the scoreboard. These connections include grounding the scoreboard, connecting the scoreboard to a power source, installing the horn, installing the ScoreLink 300 or the control cable, and connecting the control console.

Ground Connection

The National Electrical Code **requires** a scoreboard (electric sign) to be grounded. Grounding the scoreboard helps the scoreboard electronics operate properly and helps minimize damage if it is struck by lightning. Metal posts do **not** provide an adequate ground path. The following steps describe how to connect the scoreboard to the power source:

1. Drive one or more 5/8" x 8' copper clad ground rods in the soil near the scoreboard.
2. Connect #6 bare copper wire to the ground rods using 5/8" brass tear drop connectors.
3. Attach the ground conductor to the each section of the scoreboard with copper mechanical lugs. Fasten the mechanical lugs to the scoreboard using self tapping sheet metal screws.

Horn Installation

The items provided to install the horn are the horn, the weatherproof back box, the mounting bolts, and the mounting bracket. Items which are not provided but are necessary for proper installation are $\frac{3}{4}$ " flexible conduit, a $\frac{3}{4}$ " right angle male conduit connector, a $\frac{3}{4}$ " straight male conduit connector, two wires, and four forked crimp terminals. The electrical requirements for the horn are 0.35 A 120 VAC. The horn assembly is attached to the left side of the scoreboard for models with top sponsor panels. These models have two tapped holes at the mounting point. Other models may have tapped holes on the left side of the scoreboard or have one tapped hole on the top of the scoreboard at the mounting point. Mounting bolts are screwed into the tapped holes at the factory. The following steps describe the assembly and mounting of the horn:

1. Remove the mounting bolts from the scoreboard.
2. Cut a piece of $\frac{3}{4}$ " conduit of sufficient length to reach from the horn mounting point to one of the holes in the plate below the upper access panel.
3. Attach the $\frac{3}{4}$ " right angle male conduit connector to one end of the conduit and the $\frac{3}{4}$ " straight male conduit connector to the other end.
4. Cut two pieces of wire of approximately 7 feet longer than the conduit.
5. Push the wires through the conduit.
6. The horn mounting bracket has a side mount bracket attached. If the horn is going to be mounted on top of the scoreboard, remove the side mount bracket as seen in figure 5.

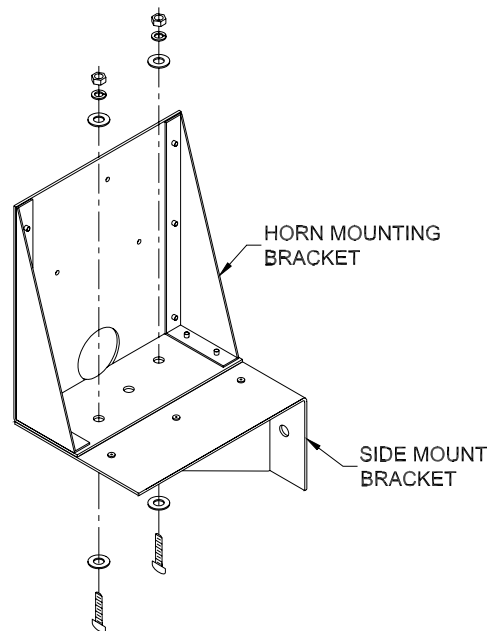

Figure 5 Side Mount Bracket Removal

7. Push the end of the conduit with the right angle male conduit connector through the 2" diameter hole in mounting bracket.
8. The weatherproof back box has two threaded conduit holes. Screw the provided conduit plug into the hole near the word "TOP" inside the weatherproof back box.

9. Feed the wires through the other back box conduit hole and screw the right angle conduit connector to the back box.
10. Attach the weatherproof back box to the mounting bracket using the provided 8-32 x 1/2" Phillips head machine screws, #8 split-lock washers, and 8-32 hex nuts as shown in figure 6.

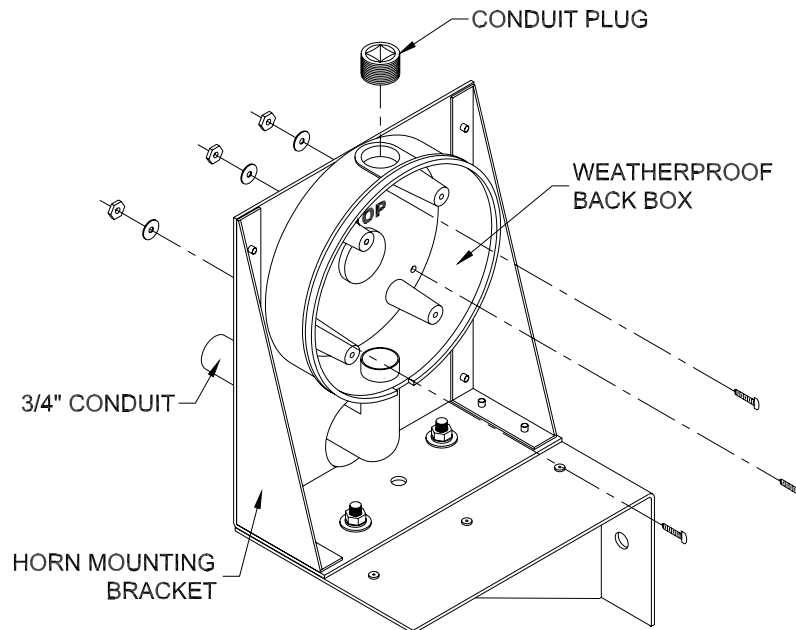

Figure 6 Back Box Mounting Points

11. Remove the horn signal mounting plate from the horn base by loosening the Phillips head screw on the base as seen in figure 7.

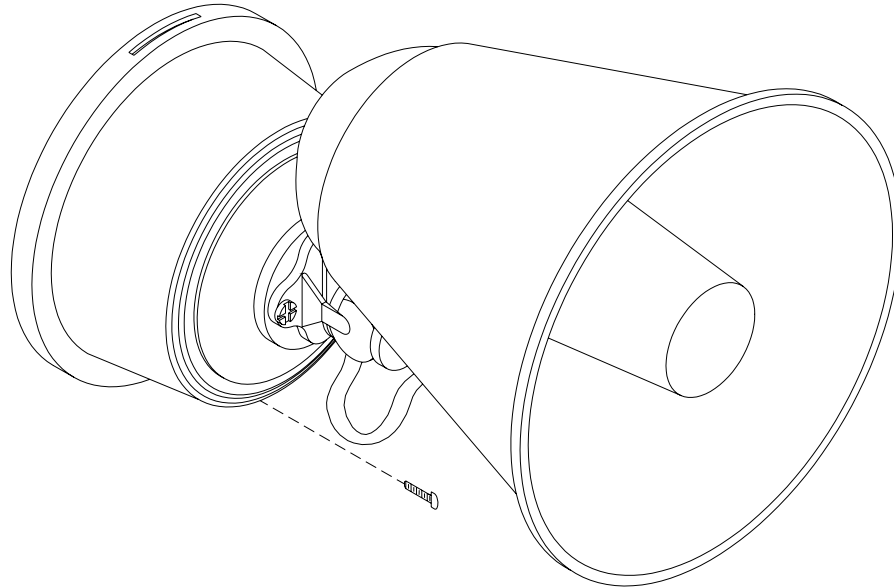

Figure 7 Horn Signal Mounting Plate Screw

12. The word “TOP” is stamped on the front side of the horn signal mounting plate. Pass the two wires that are inside the back box through the horn signal mounting plate center hole from the rear.
13. Align the horn signal mounting plate with the back box so that the word “TOP” on the horn signal mounting plate and the back box should be oriented in the same direction and the screw hole on the bottom edge of the horn signal mounting plate should be directly over the gap in the back box gasket as seen in figure 8.
14. Fasten the horn signal mounting plate with the four 8-32 x 7/16” machine screws that are provided with the back box.

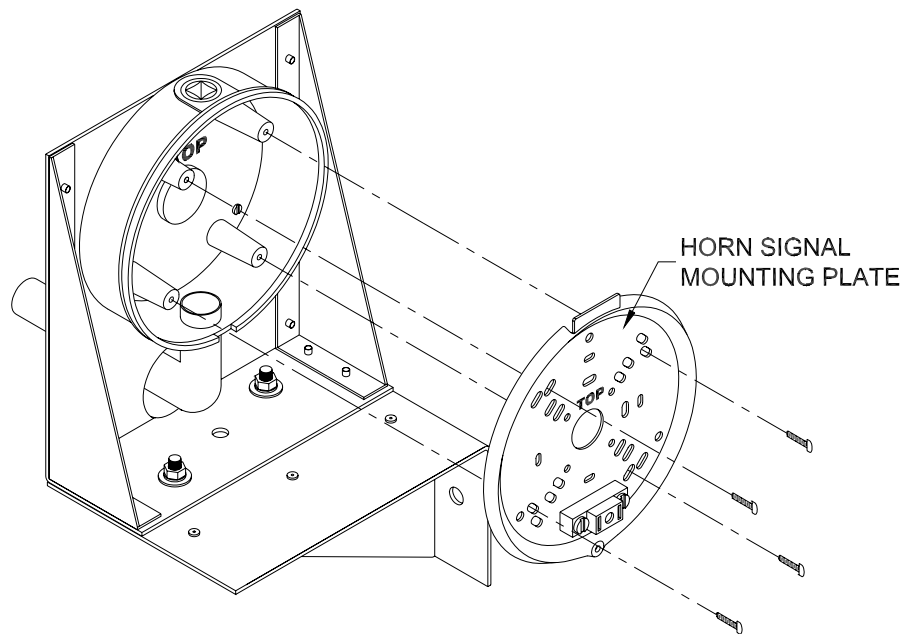

Figure 8 Horn Signal Mounting Plate Attachment

15. Crimp forked terminals on the ends of the two wires and attach them to the plug receptacle seen in figure 9.

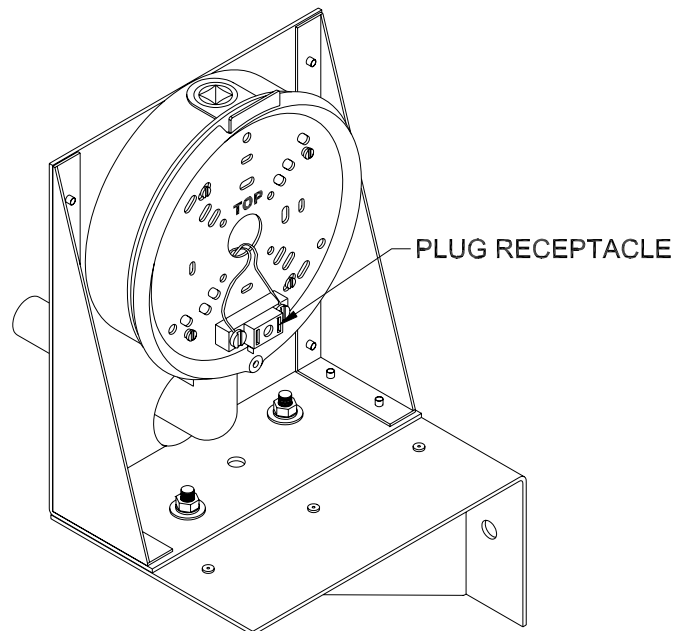
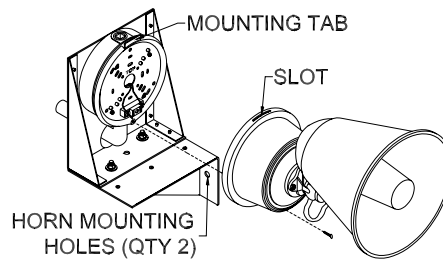

Figure 9 Plug Receptacle Wire Attachment

16. Slide the slot on the side of the horn base over the tab on the horn signal mounting plate and tighten the Phillips head screw on the other side of the horn base.
17. Fasten the horn assembly to the scoreboard using the mounting bolts from the scoreboard as seen in figure 10.

SIDE MOUNTED HORN INSTALLATION



TOP MOUNTED HORN INSTALLATION

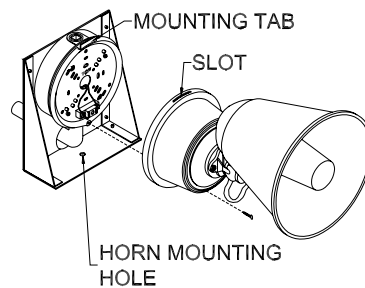

Figure 10 Horn Assembly and Mounting

18. Crimp forked terminals on the ends of the two wires that protrude out of the other end of the conduit.
19. Pass the wires through one of the holes in the plate below the upper access panel.
20. Fasten the conduit connector to the plate and connect the wires to the terminal block labeled **Horn**. Connect the AC-L wire to the left terminal and the AC-N wire to the right terminal.

Power Connection to Scoreboard

The scoreboard may be connected to 240 VAC single phase or 120 VAC service at the scoreboard. **Maximum power consumption of Model MP-374-TK: 5400 Watts.** Make sure that power cable is rated for this electrical load. Install the power cable in conduit. **Avoid** running the power cable in close proximity to the control cable. The following steps describe how to connect the scoreboard to the power source:

1. Remove the rear access panel of the upper scoreboard section and the dome plugs on the plate below the access panel. Figure 11 shows the location of the upper rear access panel and the dome plugs.

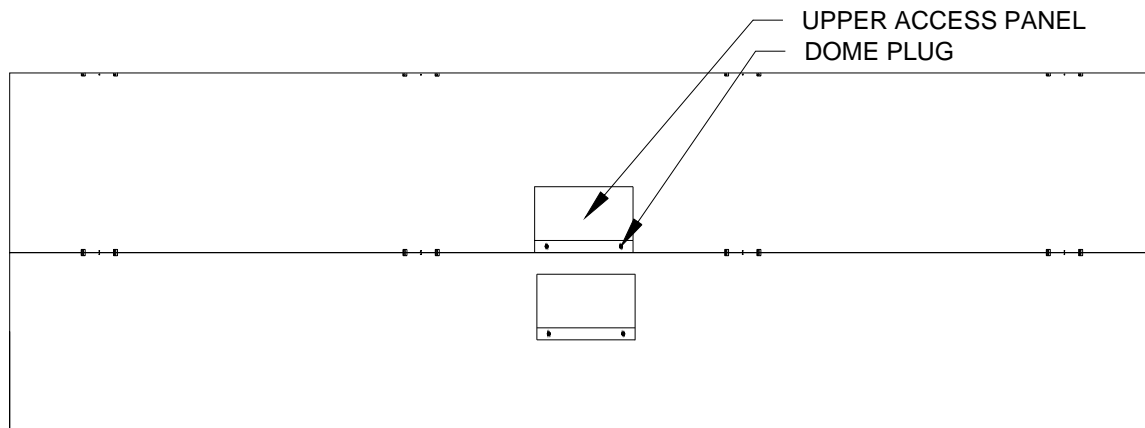

Figure 11 Upper Section Rear Access Panel

2. Figure 12 shows the view behind the access panel. Feed the power cables through one of the holes in the plate below the access panel.
3. Crimp fork terminals to the power cable wires.

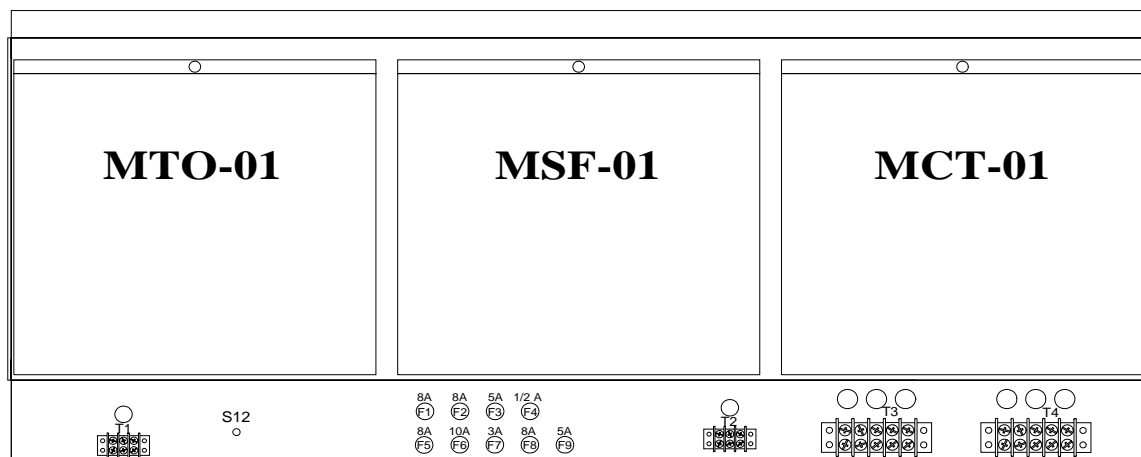

Figure 12 Upper Access Panel Removed

4. If you are going to connect the scoreboard to a 240 VAC supply, connect one AC line wire to position 2, AC neutral wire to position 3, and the other AC line wire to position 4 of terminal strip T4 on the junction chassis according to figure 13.

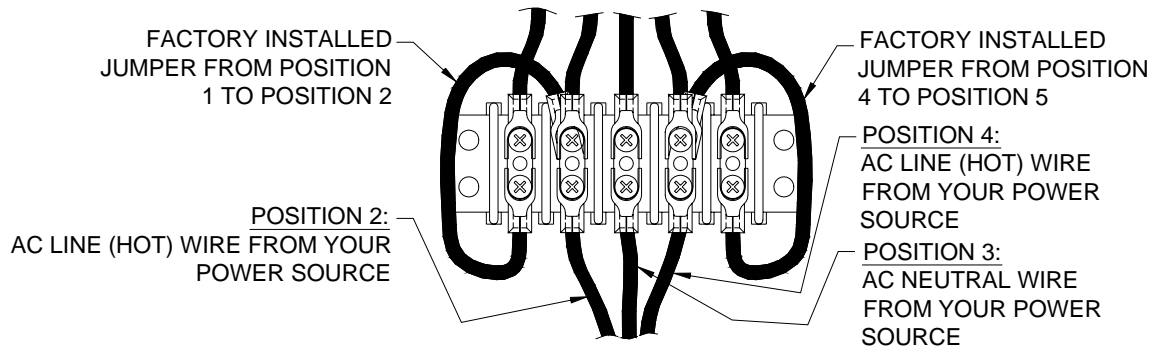

Figure 13 240 VAC Connections

- If you are going to connect the scoreboard to a 120 VAC supply, connect the AC line wire to position 2 and the AC neutral wire to position 3 of terminal strip T4 on the junction chassis. Add a jumper from position 2 to position 4. **This jumper is not provided.** Refer to figure 14.

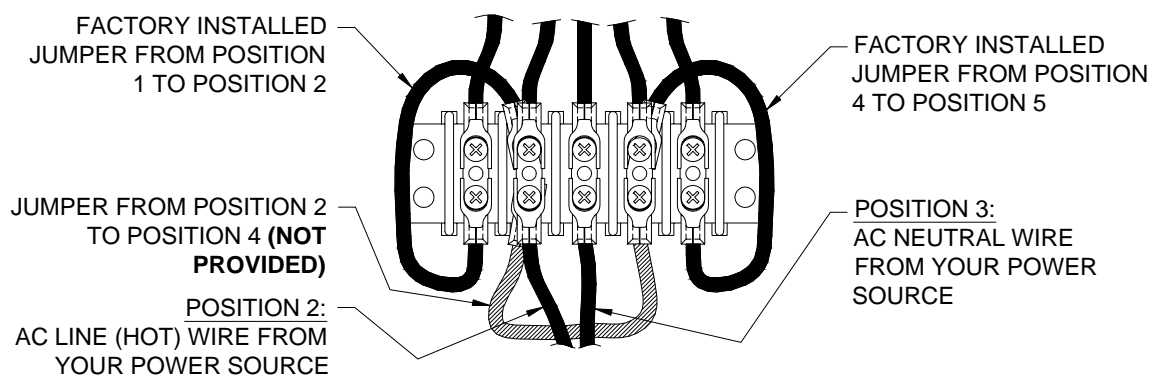

Figure 14 120 VAC Connections

Install a power disconnect that isolates all current carrying conductors on one of the posts below the scoreboard (not the ground conductor). If a secondary switch is installed near the scorekeeper's table, it should also isolate these conductors. Place the power disconnect in the **OFF** position between games to help protect the scoreboard from lightning damage. A power disconnect on the scoreboard post also provides a convenient way of turning the scoreboard off during maintenance or repairs.

ScoreLink 300

The ScoreLink 300 RF MODEM SYSTEM is designed to eliminate the control cable between the scoreboard and the control console on Electro-Mech Scoreboard MM and MP series scoreboards. If you have purchased this accessory, disregard the section of this manual titled **Control Cable Installation**. Refer to the ScoreLink 300 RF MODEM SYSTEM OWNER'S HANDBOOK for installation instructions.

Serial Data Output Connections

Customers who have purchased a set of delay of game timers can provide one unit with serial data from this scoreboard. This connection is an alternative to providing a delay of game timer with serial data from the control console via the control cable or a ScoreLink 300 RF modem. Do not connect the second delay of game timer to this scoreboard. The following steps describe how to transmit serial data from this scoreboard to one delay of game timer:

1. Remove the lower rear access panel.
2. Figure 15 shows the view behind the access pane. Feed data cable (same type of cable specified for control cable on page 3) through a hole in the plate below the access panel.

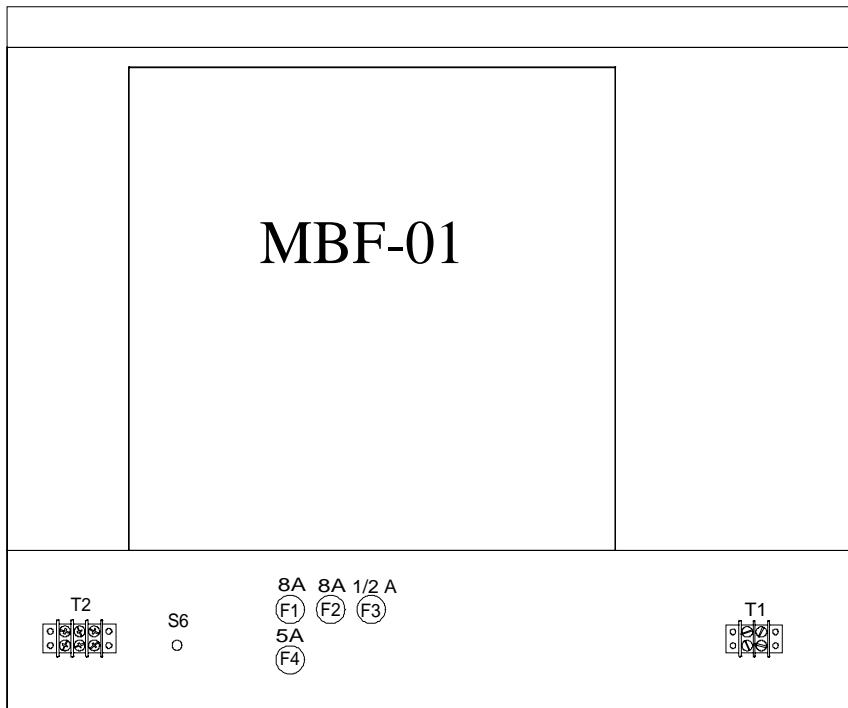
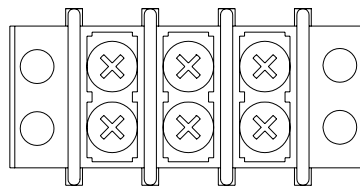

Figure 15 Lower Access Panel Removed

3. Crimp fork terminals to the cable wires and the shield.
4. Connect the cable to the T2 terminal block on the junction chassis according to figure 16.



BLACK RED SHIELD
WIRE WIRE WIRE

Figure 16 Serial Data Output Wiring Diagram

5. Remove the delay of game timer rear access panel.
6. Feed the cable through a hole in the plate below the access panel.
7. Crimp fork terminals to the cable wires and the shield.
8. Connect the cable to the terminal block labeled **Control Cable** on the delay of game timer junction chassis according to figure 17.

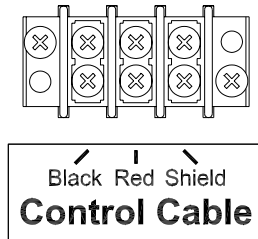
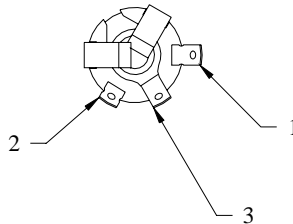

Figure 17 Control Cable Wiring Diagram

9. Reinstall the delay of game timer rear access panel.

Control Cable Installation

The control cable connects the scoreboard to the control console. Install the control cable in conduit. If the cable is ever damaged, it is easier and less expensive to replace a cable in conduit. A small junction box with a ¼" stereo jack mounted on the face plate is attached to the control cable at the point of operation of the scoreboard. This junction box should be securely mounted in a clean, dry area within ten feet of the rear of the control console. Most customers order the control cable with the junction box attached. Some customers prefer to attach the junction box after the cable is installed. Those customers must solder the control cable to the ¼" stereo jack. Figure 18 shows the control cable wire connection points on the rear of the ¼" stereo jack.



PIN 1 - BLACK WIRE
 PIN 2 - RED WIRE
 PIN 3 - SHIELD WIRE

Figure 18 ¼" Stereo Jack Wiring Diagram

The following steps describe how to connect the control cable to the scoreboard:

1. At the rear of the scoreboard feed the control cable one of the holes in the plate below the upper access panel.
2. Crimp fork terminals to the control cable wires and the shield.
3. Connect the control cable to T1 terminal block on the junction chassis according to figure 19.

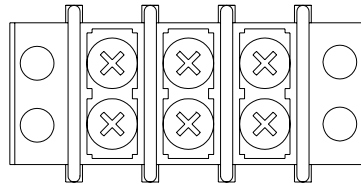

BLACK RED SHIELD
WIRE WIRE WIRE

Figure 19 Control Cable Wiring Diagram

4. Reinstall the access panels.

Control Console Connections

The 10 ft. extension cable has two molded ¼” stereo plugs attached to it. It is used to connect the control console to the junction box. The following steps describe how to connect the control console:

1. Plug one end of the extension cable into ¼” stereo jack on the junction box or the ScoreLink 300 Transmitter, if purchased.
2. Plug the other end into the ¼” stereo jack mounted on the control console back plate.
3. Plug the control console power cord into a grounded NEMA 5-15R 120 VAC receptacle.

Control Console Safety Warning

This product is equipped with a 3-wire grounding type plug, a plug having a third (grounding) pin. This plug will only fit into a grounding-type power outlet. This is a safety feature. If you are unable to insert the plug into the outlet, contact a qualified electrician to replace your obsolete outlet. Do not defeat the purpose of the grounding-type plug.

SCOREBOARD OPERATION

SCOREBOARD STARTUP

1. Place the power disconnect for the scoreboard in the **ON** position.
2. Plug one end of the extension cable into ¼” stereo jack on the junction box or the ScoreLink 300 Transmitter, if purchased.
3. Plug the other end into the ¼” stereo jack mounted on the control console back plate.
4. Plug the control console power cord into a grounded NEMA 5-15R 120 VAC receptacle.
5. If a ScoreLink 300 RF MODEM SYSTEM is installed with this scoreboard, plug the wall mount DC power supply into a grounded NEMA 5-15R 120 VAC receptacle and the male plug on the end of the attached cable into the Power jack on the Transmitter.

GAME TIME OPERATION

This scoreboard is operated with a 37-key control console. Figure 20 shows the keypad layout on the control console.

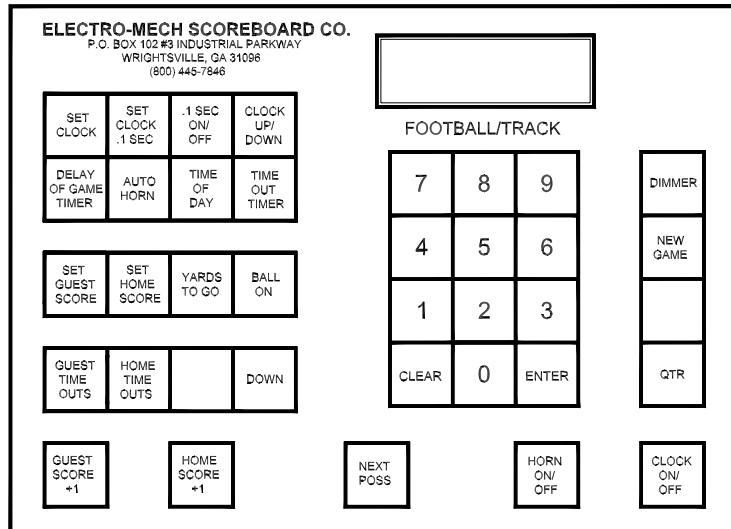

Figure 20 Keypad Layout

Immediately after the control console power cord is plugged into a 120 VAC source, the console LCD display will read:

```
ELECTRO-MECH VER
SCOREBOARD T17
```

After a few seconds the display will read:

```
00 D15:00.0 0 0 00
4 00 00 0 4
```

The scoreboard will display:

CLOCK – 15:00.0
 GUEST SCORE – 0
 HOME SCORE – 0
 YDS. TO GO – 0
 BALL ON – 0
 GUEST TIME OUTS – 4
 HOME TIME OUTS – 4

The control console LCD display shows the same information as the scoreboard. Note: In some functions a 0 will be blanked on the scoreboard, but not on the console. Figure 21 explains the LCD display layout.

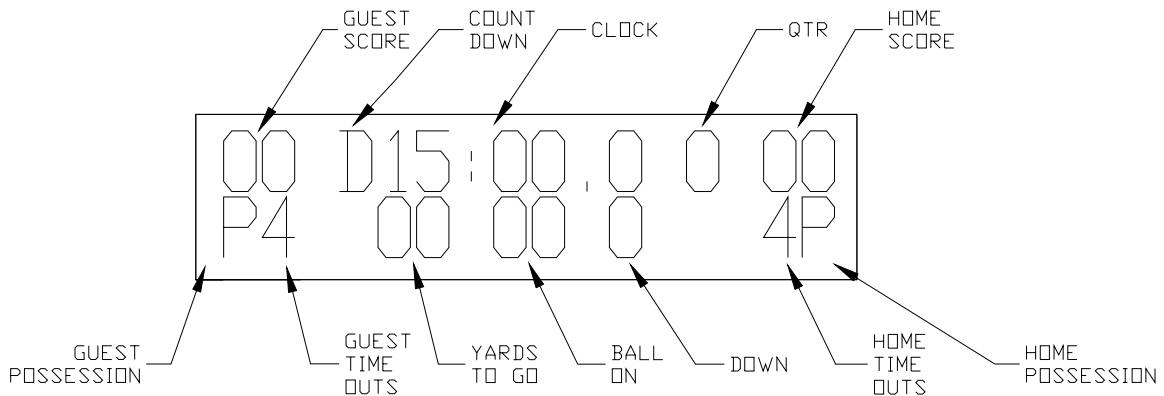

Figure 21 Control Console LCD Display

Control Console Key Functions

1. **SET CLOCK** – This key sets the time displayed on the scoreboard clock. Press [SET CLOCK]. The console LCD display will read:

```
00 D15: 00.0 0 0 00
SET CLK <00: 00>
```

Press the keypad numbers for the time, [ENTER]. Example: Press [SET CLOCK], [6], [0], [0], [0], [ENTER] on the control console. 60:00 will be displayed on the clock section of the scoreboard.

2. **SET CLOCK .1 SEC** – This key is used to set the scoreboard clock when tenth of a second accuracy is required. Press [SET CLOCK .1 SEC]. The console LCD display will read:

```
00 D15: 00.0 0 0 00
SET CLK<00: 00. 0>
```

Press the keypad numbers for the time, [ENTER]. Example: Press [SET CLOCK .1 SEC], [5], [3], [8], [ENTER] on the control console. 53.8 will be displayed on the clock section of the scoreboard.

3. **.1 SEC ON/OFF** – This key is used to enable or disable the display of tenths of seconds on the scoreboard. This mode is enabled when the control console is turned on. If it is disabled, the LCD display on the control console will still show 1/10th second timing, but the scoreboard will not display it. To turn this function off, press [.1 SEC ON/OFF]. The console LCD display will read:

```
CLOCK   ON   <1>
.1 SEC  OFF  <0>
```

Press [0], [ENTER] on the control console.

4. **CLOCK UP/DOWN** – The clock can be set up to either count up or count down. The control console is set to the clock down mode when it is turned on. To make the clock count up, press [CLOCK UP / DOWN]. The console LCD display will read:

```
GAME     UP   <1>
CLOCK    DOWN <0>
```

Press [1], [ENTER] on the control console. The letter D in front of the game time on the console LCD will be replaced with the letter U to indicate that the clock is in the count up mode. To reset the clock to count down mode, press [CLOCK UP / DOWN], [0], [ENTER] on the control console.

5. **DELAY OF GAME TIMER** – The console is programmed with two delay of game timers. The delay of game timers should be set prior to the start of a game. Delay of Game Timer 1 is preset to 30 seconds. Delay of Game Timer 2 is preset to 5 seconds. To change either one of these times, press [DELAY OF GAME TIMER]. The console LCD display will read:

```
00 D15: 00.0 0 00
DELAY TIME1 <30>
```

Press the keypad numbers to set Delay of Game Timer 1, [ENTER]. The LCD display will then read:

```
00 D15: 00.0 0 00
DELAY TIME2 <05>
```

Press the keypad numbers to set Delay of Game Timer 2, [ENTER].

6. **AUTO HORN** – This key allows the operator to control the end of period horn and the time out horn. The horn sounds for two seconds when the clock reaches 0:00 at the end of the period. The end of period horn can be disabled by pressing [AUTO HORN]. The console LCD display will read:

```
GAME PRESS<1>ON
HORN PRESS<0>OFF
```

Press [0], [ENTER] to disable the horn. The console LCD display will then read:

```
T-0 PRESS<1>ON
HORN PRESS<0>OFF
```

The time out horn is normally disabled. To enable the horn to sound at the end of the time out, press [1], [ENTER] on the control console.

7. **TIME OF DAY** – The time of day can be displayed on the clock section of the scoreboard. **THE GAME CLOCK WILL BE INOPERABLE UNTIL THE TIME OF DAY FUNCTION IS TURNED OFF.** To turn the time of day clock on, press [TIME OF DAY]. The console LCD display will read:

```
TIME OF ON <1>
DAY CLOCK OFF<0>
```

Press [1], [ENTER] on the control console. The console LCD display will then read:

```
00 C12:00 0 00
SET CLK <12:00>
```

Press the keypad numbers for the time, [ENTER]. The letter C will be displayed on the console LCD display to the left of the time to indicate that the time of day function is active. The scoreboard will display the time of day.

8. **TIME OUT TIMER** – To set the Time Out Timer, press [TIME OUT TIMER]. The console LCD display will read:

```
00 D15:00.0 0 00
SET T-0 <1:00>
```

Press the keypad numbers for the time, [ENTER]. After the ENTER key is pressed, the letter T is displayed to the left of the time on the LCD display and the Time Out Timer immediately begins to count down to 0. The scoreboard will not display the Time Out time. To exit the Time Out Timer function before 0, press [TIME OUT TIMER], [ENTER].

9. **SET GUEST SCORE** – To set the guest score, press [SET GUEST SCORE]. The console LCD display will read:

```
00 D15: 00.0 0 0 00
GUEST SCORE <00>
```

Press the keypad numbers for the score, [ENTER]. EXAMPLE: To set the visitor score to 53, press [SET GUEST SCORE], [5], [3], [ENTER].

10. **SET HOME SCORE** – To set the home score, press [SET HOME SCORE]. The console LCD display will read:

```
00 D15: 00.0 0 0 00
HOME SCORE <00>
```

Press the keypad numbers for the score, [ENTER]. EXAMPLE: To set the home score to 75, press [SET HOME SCORE], [7], [5], [ENTER].

11. **YARDS TO GO** – To set the yards to go, press [YARDS TO GO]. The console LCD display will read:

```
00 D15: 00.0 0 0 00
YARDS TO GO <00>
```

Press the keypad numbers for the yards, [ENTER]. EXAMPLE: To set the yards to go to 10, press [YARDS TO GO], [1], [0], [ENTER].

12. **BALL ON** – To display the position of the ball on the field, press [BALL ON]. The console LCD display will read:

```
00 D15: 00.0 0 0 00
BALL ON <00>
```

Press the keypad numbers for the position, [ENTER]. EXAMPLE: To display that the ball is on the 35 yard line, press [BALL ON], [3], [5], [ENTER].

13. **GUEST TIME OUTS** – This key decrements the Guest time outs by 1. Each team starts with four time outs. If this key is pressed when GUEST TIME OUTS displays 0, it will change to 4.
14. **HOME TIME OUTS** – This key decrements the HOME time outs by 1. Each team starts with four time outs. If this key is pressed when HOME TIME OUTS displays 0, it will change to 4.
15. **DOWN** – This key increments the DOWN by 1. If this key is pressed when DOWN displays 4, the digit will be blanked.
16. **GUEST SCORE +1** – This key increments the Guest score by 1.
17. **HOME SCORE +1** – This key increments the Home score by 1.
18. **NEXT POSS** – This key toggles the possession indicators between Guest and Home.
19. **HORN ON/OFF** – This key is used to sound the horn for ½ second.
20. **CLOCK ON/OFF** – This key is used to start and stop the clock.

21. **QTR** – This key is used to increment the quarter by 1.
22. **NEW GAME** – This key is used to reset all the scoreboard functions to their default settings. To reset the scoreboard, press [NEW GAME]. The console LCD display will read:

RESET	YES<1>
SCOREBOARD	NO<0>

Press [1], [ENTER] on the control console. The scoreboard will reset its functions.

23. **DIMMER** – This key will dim all the scoreboard lamps. To dim the scoreboard lamps, press [DIMMER]. The console LCD display will read:

DIMMER	YES<1>
ON	NO<0>

24. Press [1], [ENTER] on the control console. The scoreboard lamps will dim.

Hand Held Clock Control Unit Operation

The hand held clock control unit has an attached cable that is plugged into a jack on the control console back plate labeled **Clock Hand held**. It has one button that is used to toggle the clock on and off.

You should reset the scoreboard each time that it is turned on. Test out all the functions to ensure that the scoreboard is operating properly.

SCOREBOARD SHUTDOWN

1. Place the power disconnect for the scoreboard in the **OFF** position.
2. Unplug the control console power cord.
3. Unplug the extension cable.
4. If a ScoreLink 300 RF MODEM SYSTEM is installed with this scoreboard, unplug the Transmitter's wall mount power supply.
5. Store the control console and ScoreLink 300 Transmitter in a dry location. These units are not waterproof.

Proper scoreboard shutdown will help protect the scoreboard and control console from power surges and lightning strikes.

SERVICING THE SCOREBOARD

While your scoreboard was designed for years of trouble-free operation, some problems may occasionally occur. Electro-Mech Scoreboard Company offers onsite service in some areas. In other areas, we can help you contact an independent service technician. In areas in which service is not available from Electro-Mech Scoreboard Company, we will make every effort to answer your questions. Our trained personnel at Electro-Mech Scoreboard Company are ready to answer your questions from Monday to Friday during the hours of 8 AM to 5 PM Eastern Standard Time. Be sure to know your scoreboard model number when calling. Scoreboard replacement parts are always available. Damaged parts can usually be repaired at a significant cost savings. Our convenient toll free number is listed at the bottom of every page in this manual.

TROUBLESHOOTING TIPS

Before calling Electro-Mech Scoreboard Co. for customer support of a scoreboard problem, it is helpful to make note of all the symptoms. If the scoreboard does not turn on lamps, please check the following items:

1. Make sure the control console power cord and the extension cable are plugged.
2. Verify that the control console LCD display shows game information.
3. Press control console keys and look for changes on the game information shown on the LCD display.
4. Check the circuit breaker that supplies power to the scoreboard.
5. Remove the upper access panel cover and check the voltages present at main power terminal block.
6. Check the fuses.
7. Take the control console and the extension cable to the scoreboard. Temporarily disconnect the control cable from the main control terminal block and plug the extension cable into the test jack. Plug the control console power cord into a 120 VAC receptacle. If the lamps are now illuminated and the scoreboard reacts to control console entries, there may be a problem with the control cable or the ScoreLink 300 modem, if purchased.

If the scoreboard turns on lamps, but does not operate normally, make note of which functions are affected. If some lamps either never turn on or always stay on, make note of their specific locations on the scoreboard. Refer to the LAMP REPLACEMENT section of this manual before changing lamps.

COMPONENT REPLACEMENT

LAMP REPLACEMENT

Remove the protective mask covering each lamp bank to access the lamps. **To avoid damage to the plug in module, always turn off the power to the scoreboard when changing lamps.** We recommend using a felt pen or tape to mark lamps that will not light. The scoreboard uses 15 watt 120 VAC frosted medium based appliance lamps (also known as 15A15IF lamps). **Never replace these with higher wattage lamps.**

Figure 22 shows the components behind the upper access panel.

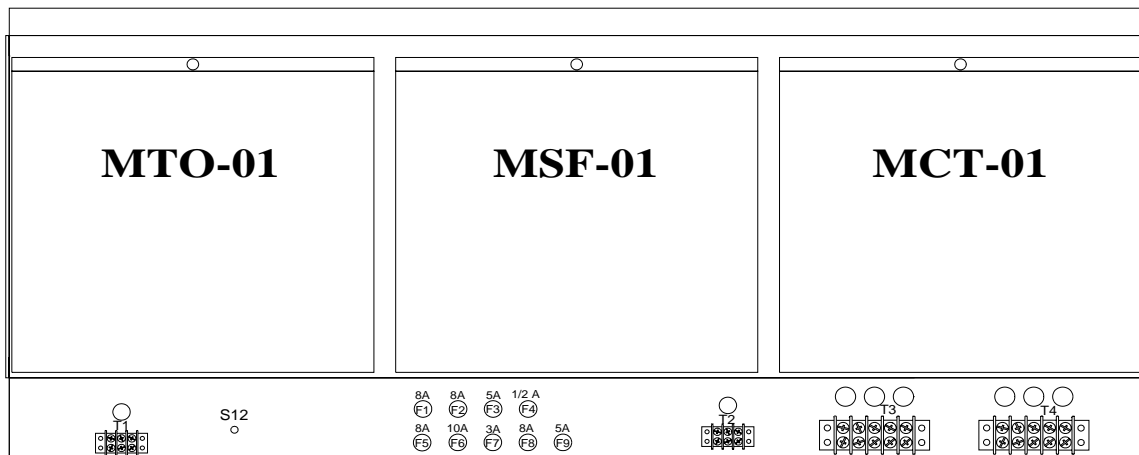

Figure 22 Upper Access Panel Components

The electronics that control functions in the upper section of the scoreboard are enclosed in three plug-in modules. The plug in module MTO-01 operates VISITOR TIME OUTS and HOME TIME OUTS. The plug in module MSF-01 operates VISITOR SCORE, HOME SCORE, 0.1 SECOND digit of the TIME, VISITOR POSSESSION, and HOME POSSESSION. The plug in module MCT-01 operates the TIME (except the 0.1 SECOND digit), QTR., and horn. The main power and control connection points are located on the junction chassis behind the access panel. The tables below list the fuses and electrical connection points that are mounted on the junction chassis. Always replace the fuses with replacements of the same type and rating.

FUSES

FUSE	RATING	FUNCTION	BUSSMAN PART #
F1	8A 250V	GUEST SCORE	AGC-8
F2	8A 250V	HOME SCORE	AGC-8
F3	5A 250V	HOME & GUEST POSSESSION	AGC-5
F4	½A 250V	CONTROL LINE	AGC-1/2
F5	8A 250V	MINUTES	AGC-8
F6	10A 250V	SECONDS	AGC-10
F7	3A 250V	HORN	AGC-3
F8	8A 250V	TIME OUTS	AGC-8
F9	5A 250V	QUARTER	AGC-5

Note: Other manufacturers' fuses may be substituted for the Bussmann fuses.

CONNECTION POINTS

TERMINAL STRIP	FUNCTION
T-1	control cable connection
T-2	power cable to horn
T-3	MOV (surge protection)
T-4	power cable connection
S-12	test jack

Figure 23 shows the components behind the lower access panel.

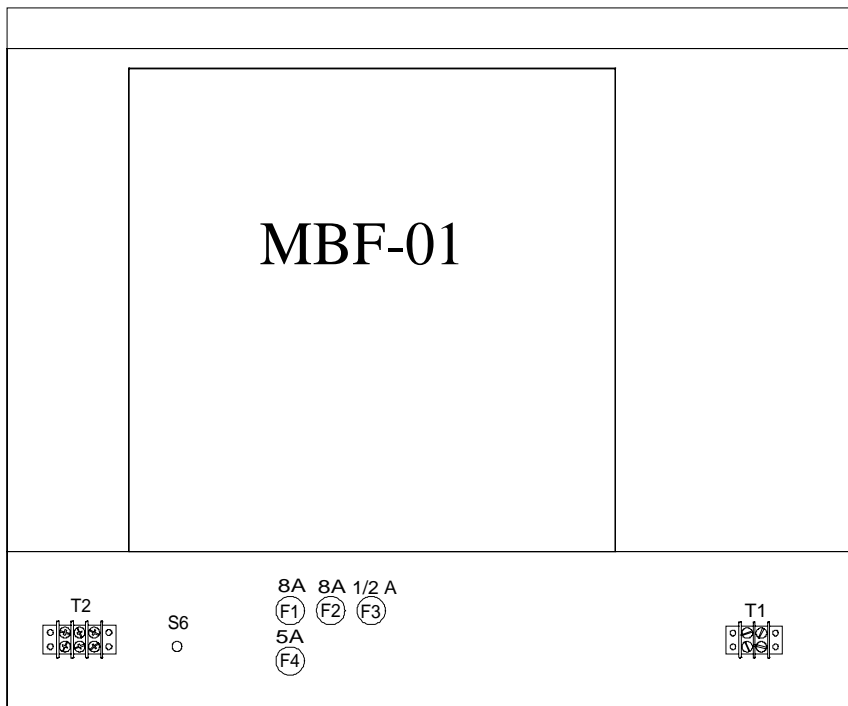

Figure 23 Lower Access Panel Components

The plug in module MBF-01 operates DOWN, BALL ON and YDS. TO GO. T-1 is not normally used. It can be used to help troubleshoot a scoreboard that has no power to the lower section.

FUSES

FUSE	RATING	FUNCTION	BUSSMAN PART #
F1	8A 250V	BALL ON	AGC-8
F2	8A 250V	YARDS TO GO	AGC-8
F3	1/2A 250V	CONTROL LINE	AGC-1/2
F4	5A 250V	DOWN	AGC-5

Note: Other manufacturers' fuses may be substituted for the Bussmann fuses.

CONNECTION POINTS

TERMINAL STRIP	FUNCTION
T-1	test power connection
T-2	serial data output connection
S-6	test jack

PLUG IN MODULE REPLACEMENT

Each module has bottom plugs that mate with sockets in the scoreboard. A screw located at the top of the module holds it against the scoreboard cabinet. Simply remove the screw and pull the module upward to unseat the module. **To avoid damage to the plug in module, always turn off the power to the scoreboard when removing or replacing it.**

ELECTRO-MECH SCOREBOARD CO. FIVE YEAR LIMITED WARRANTY

THE ELECTRICAL COMPONENTS OF ALL ELECTRO-MECH SCOREBOARDS ARE GUARANTEED FOR A PERIOD OF FIVE (5) YEARS FROM THE DATE OF INVOICE AGAINST DEFECTS IN WORKMANSHIP OR MATERIAL AND WILL BE REPLACED OR REPAIRED WITHOUT COST TO THE OWNER PROVIDED THE EQUIPMENT OR PARTS ARE RETURNED POSTAGE-PAID TO THE FACTORY IN WRIGHTSVILLE, GA. SHIPPING BACK TO THE OWNER WILL BE VIA UPS GROUND SERVICE EXCEPT WHEN AIR OR SPECIAL METHOD OF RETURN IS SPECIFIED BY THE OWNER, IN WHICH CASE SHIPPING WILL BE FREIGHT COLLECT.

EXCLUDED FROM THIS WARRANTY ARE LAMPS, FUSES AND SOCKETS.

THIS WARRANTY DOES NOT INCLUDE LABOR CHARGES INCURRED IN THE REMOVAL OF COMPONENT PARTS, SERVICE CALLS, OR DAMAGES RESULTING FROM IMPROPER INSTALLATION, IMPROPER OPERATION, OR PROBLEMS CAUSED BY ANY REPAIR, ALTERATION OR MODIFICATION OF THE SCOREBOARD NOT PERFORMED BY ELECTRO-MECH.

EQUIPMENT WHICH IS SUBJECTED TO ACCIDENT, NEGLIGENCE, ABUSE, MISUSE OR OTHER NATURAL DISASTERS, INCLUDING BUT NOT LIMITED TO FIRE, WIND, LIGHTNING, OR FLOOD, IS NOT COVERED BY THIS GUARANTEE.