

---

## ELECTRO-MECH SCOREBOARD CO.

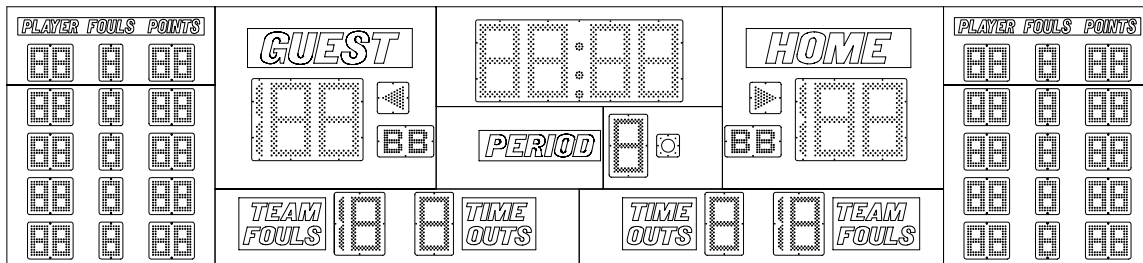

## MODEL 2577 BASKETBALL SCOREBOARD

### OWNER'S HANDBOOK

Thank you for choosing an Electro-Mech Scoreboard for your athletic complex. We are confident that your new scoreboard will give many years of reliable service.

Rev. 3 Revised: 10/04/2006

## TABLE OF CONTENTS

<b>2577 BASKETBALL SCOREBOARD SPECIFICATIONS.....</b>	<b>3</b>
<b>SCOREBOARD INSTALLATION.....</b>	<b>4</b>
<b>MECHANICAL INSTALLATION.....</b>	<b>5</b>
Mounting the Scoreboard .....	5
Attaching the Optional Bottom Sponsor Panel.....	6
<b>ELECTRICAL INSTALLATION.....</b>	<b>6</b>
Power Connection .....	6
ScoreLink 200.....	7
Control Cable Installation.....	7
Control Console Connections .....	8
Control Console Safety Warning.....	9
Goal Lights Installation.....	9
Installation of Two or More Scoreboards at the Same Site .....	9
<b>SCOREBOARD OPERATION .....</b>	<b>10</b>
<b>SCOREBOARD STARTUP.....</b>	<b>10</b>
<b>GAME TIME OPERATION .....</b>	<b>11</b>
2550 Control Console Key Functions.....	12
2057 Control Console Key Functions.....	17
Horn and Goal Lights Operation .....	19
Hand Held Clock Control Unit Operation .....	19
<b>SCOREBOARD SHUTDOWN .....</b>	<b>19</b>
<b>SERVICING THE SCOREBOARD .....</b>	<b>19</b>
<b>COMPONENT REPLACEMENT .....</b>	<b>20</b>
LED Digits And Indicators Replacement .....	20
Horn Replacement .....	22
LED Driver Module Replacement.....	23
LED Power Supply Module Replacement .....	25
LED Power Interface Board Replacement .....	27
LED Extra Digit Interface Board Replacement.....	27
<b>WARRANTY.....</b>	<b>29</b>

## 2577 BASKETBALL SCOREBOARD SPECIFICATIONS

**GENERAL:** This ETL listed scoreboard includes the scoreboard cabinet, mounting hardware, three control consoles, three 10 ft. extension cables, and three junction boxes.

**DIMENSIONS:** 22' L x 5' H x 6" D (The optional bottom sponsor panel measures 22' L x 21" H x 6" D)

**WEIGHT:** 280 lbs (The optional bottom sponsor panel weighs 100 lbs)

**SCOREBOARD CONSTRUCTION:** The outer frame is made from extruded aluminum. Internal structural parts may be extruded aluminum or formed from aluminum sheet. The face and back are made from aluminum sheet. The face is finished with enamel paint. Black is the standard face color. White is the standard color for the sponsor panel. The captions are white on a gray background. The optional bottom sponsor panel is mounted on a separate extruded aluminum frame.

**DISPLAY:** The 2577 basketball scoreboard displays HOME and GUEST scores 0 to 199, team fouls 0 to 19, bonus and possession symbols, time outs 0 to 9, player number 0 to 99, fouls 0 to 9, and points 0 to 99 for the five players currently in the game, a 99:59 clock with 1/10<sup>th</sup> of a second timing below 1:00, and PERIOD 1 to 4. It has an internal horn.

**DIGITS AND SYMBOLS:** Light emitting diodes mounted on printed circuit boards form the digits and symbols. The clock uses 16" red digits, the HOME and GUEST scores use 16" yellow digits, the PERIOD uses a 12" green digit, 5" bonus symbols are green, the 5" possession symbols and colon / decimal symbols are red, the team fouls use 12" yellow digits, the time outs use 12" red digits, the player numbers use 6" red digits, the player fouls use 6" green digits, and the player points use 6" yellow digits.

**POWER REQUIREMENTS:** **Scoreboard** - 120 VAC, 3 A, 60 Hz. The scoreboard has an attached 9 ft. power cord. **Control Consoles** - 120 VAC, 0.5 A, 60 Hz each

**SCOREBOARD ELECTRONICS:** 100% solid state fully enclosed.

**CONTROL CONSOLES:** Each control console features a microprocessor, 37 key sealed membrane keypad, a LCD display, and an attached 6 foot power cord. The console housing consists of ABS plastic base and top pieces with a steel back plate.

**CONTROL CABLES:** Each cable has two 22 AWG stranded copper conductors with semi-rigid PVC insulation. It also has a braided shield and a foil shield. The polyethylene jacket is rated at 300 volts. The cable is direct burial rated and measures approximately 1/4" in diameter. Three control cables needed for installation. The cable is sold separately from the scoreboard.

**JUNCTION BOXES AND EXTENSION CABLES:** A 4 1/4" x 2 1/4" x 2" junction box with a 1/4" stereo jack mounted on the face plate is attached to each control cable at the point of operation. 10 ft. extension cables connect the control consoles to the junction boxes.

**SCORELINK 200 RF MODEM SYSTEM:** This accessory can be used in place of control cables and junction boxes for this scoreboard without internal modifications to the scoreboard or the control consoles. Three sets of transmitters and receivers are needed for installation. Refer to the SCORELINK 200 RF MODEM SYSTEM OWNER'S HANDBOOK for more information.

**WARRANTY:** Five year limited warranty.

## SCOREBOARD INSTALLATION

This part of the manual describes the mechanical and electrical installation of the scoreboard. Figure 1 shows a typical installation of the scoreboard in a gym.

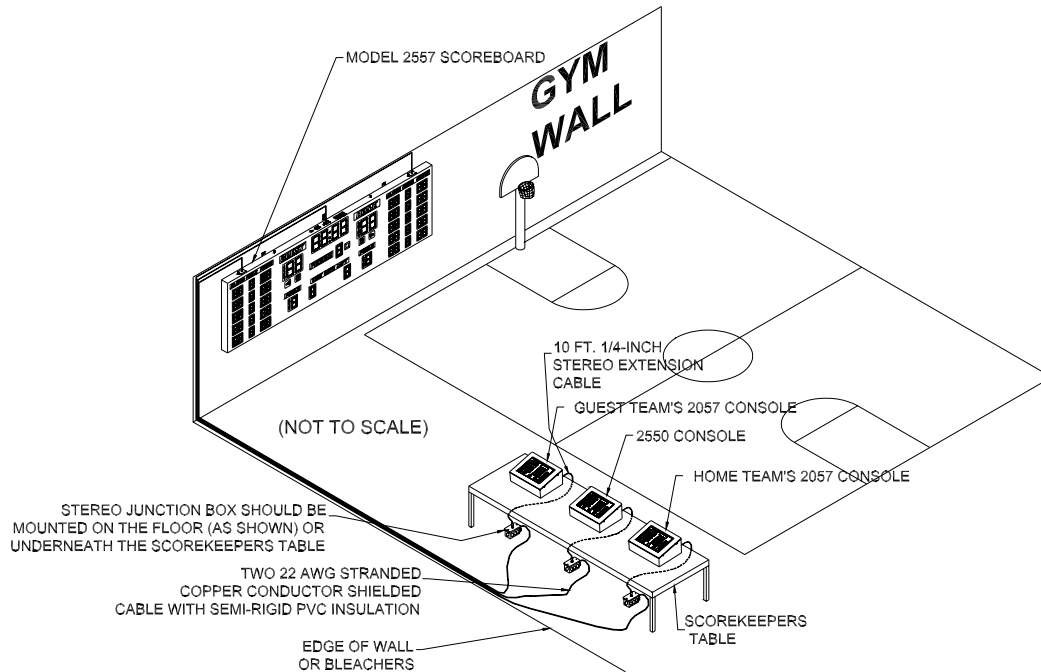

**Figure 1 Typical Installation**

One of the items listed below must be purchased in order to complete the installation:

- Control cable (length dependent upon installation site layout, but not to exceed 1000 feet between a console and the scoreboard)
- ScoreLink 200 RF Modem System (3 sets required on separate channels)

Items not provided by Electro-Mech Scoreboard Company that are necessary for installation:

- Wall fasteners
- Grounded NEMA 5-15R 120 VAC receptacles for the 3 control consoles at the scorekeeper's table.

Electro-Mech Scoreboard Company performs installations in some areas. In other areas, we can help you contact an independent installer. In areas in which installation service is not available from Electro-Mech Scoreboard Company, we will make every effort to answer your installation questions. Qualified personnel should perform the scoreboard installation. Consult national and local codes before installation.

## MECHANICAL INSTALLATION

The mechanical installation includes mounting the scoreboard on the wall and attaching the optional bottom sponsor panel (if purchased) to the scoreboard.

### Mounting the Scoreboard

The following steps describe how to mount the scoreboard on the wall:

1. There are two hanger brackets attached to the scoreboard near the top of the cabinet on the rear side. They may have been rotated down to facilitate shipping. Rotate the hanger brackets so that they protrude past the top of the scoreboard and tighten the bolts.
2. Lift the scoreboard to the desired location. There are two eyebolts mounted at the top of the cabinet that can be used to lift the scoreboard into place. **Be sure to mount the center of the scoreboard close enough to the wall receptacle so that you can plug in the 9 ft. power cord.**
3. Insert lag bolts or other suitable fasteners through the hanger brackets and fasten the scoreboard to the wall. Figure 2 shows the mounting point locations for model 2577.

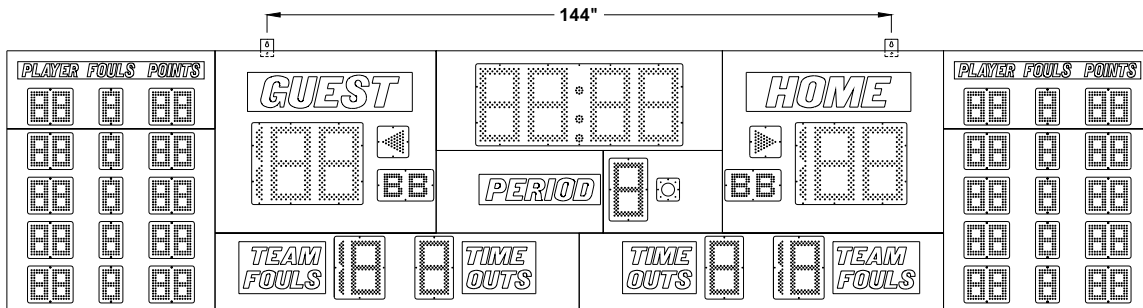

Figure 2 Model 2577 Mounting Points

### Attaching the Optional Bottom Sponsor Panel

Two attachment plates, four bolts, and four washers are provided to attach the sponsor panel to the bottom of the scoreboard. The attachment points are located on the sides of the scoreboard and sponsor panel cabinets. The following steps describe how to attach the sponsor panel to the scoreboard:

1. Raise the sponsor panel to the bottom of the scoreboard.
2. Fasten an attachment plate to the right side of the scoreboard and sponsor panel using the provided washers and bolts as shown in figure 3.
3. Fasten the other attachment plate to the left side of the scoreboard and sponsor panel in the same manner.

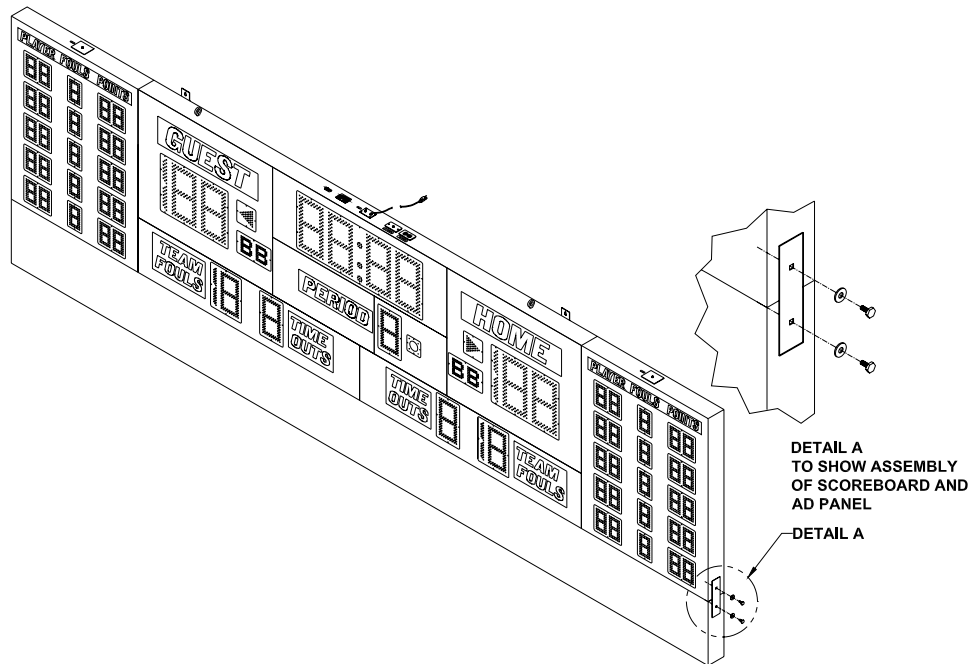

Figure 3 2577 with Bottom Sponsor Panel Attached

### ELECTRICAL INSTALLATION

We recommend a qualified electrician perform the needed electrical connections to ensure proper operation of the scoreboard. These connections include connecting the scoreboard to a power source, installing the ScoreLink 200 sets or the control cables, and connecting the control consoles. The installation of goal lights and multiple scoreboards at the same site is also described in this section.

#### Power Connection

The scoreboard requires 120 VAC service at the scoreboard to operate properly. **Maximum power consumption of Model 2577: 360 Watts.** The scoreboard has a 9 ft. attached power cord located at the top of the cabinet. Plug the power cord into a grounded NEMA 5-15R receptacle. The receptacle should be controlled by a separate circuit breaker so that the scoreboard can be turned off without turning off other electrical devices in the facility. Figure 4 shows the electrical connection points on the scoreboard.

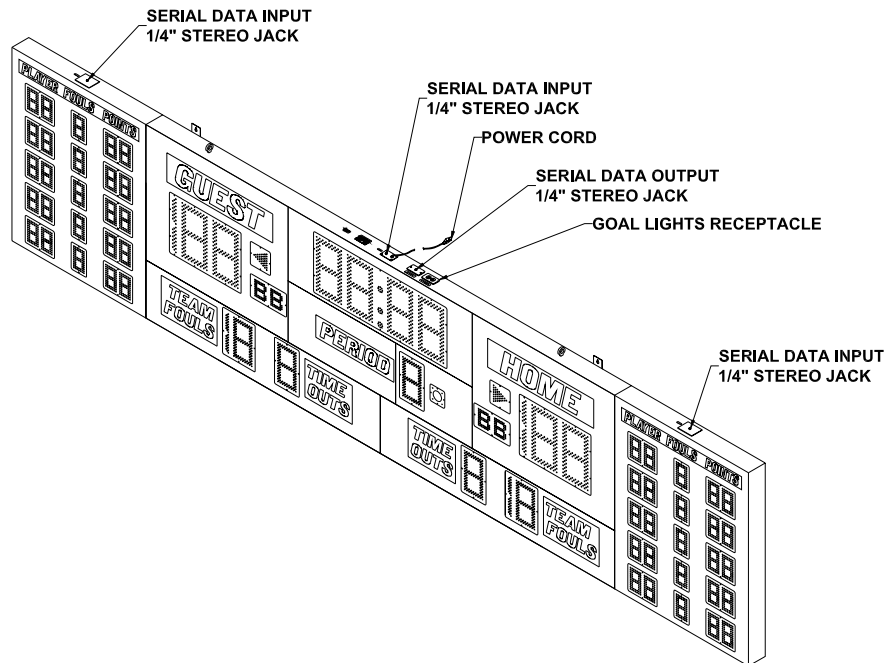

**Figure 4 Electrical Connection Points**

### ScoreLink 200

The SCORELINK 200 RF MODEM SYSTEM is intended to eliminate the control cable between the scoreboard and the control console on indoor Electro-Mech Scoreboard MM and MP series scoreboards. If you have purchased this accessory, disregard the section of this manual titled **Control Cable Installation**. Three sets of transmitters and receivers programmed on different channels are required for this scoreboard. Refer to the SCORELINK 200 RF MODEM SYSTEM OWNER'S HANDBOOK for installation instructions.

### Control Cable Installation

Three control cables must be installed for this scoreboard. These cables must not be connected together at any point. No cable lengths should exceed 1000 feet. The control cables allow data to be transmitted from the control consoles to the scoreboard. Install one control cable from the SERIAL DATA INPUT 1/4" stereo jack on the top of the scoreboard above the GUEST STAT PANEL section (left end of the scoreboard) to within 10 feet of the GUEST TEAM'S 2057 control console. Install the second control cable from the SERIAL DATA INPUT 1/4" stereo jack on top of the scoreboard above the game clock (middle of the scoreboard) to within 10 feet of the 2550 control console. Install the third control cable from the SERIAL DATA INPUT 1/4" stereo jack on the top of the scoreboard above the HOME STAT PANEL section (right end of the scoreboard) to within 10 feet of the HOME TEAM'S 2057 control console. A small junction box with a 1/4" stereo jack mounted on the face plate is attached to each control cable at the point of operation of the scoreboard. These junction boxes should be securely mounted within ten feet of the rear of the control consoles. Most customers order the control cables with the junction boxes attached. Some customers prefer to attach the junction boxes after the cables are installed. Those customers must solder the control cables to the 1/4" stereo jacks. Figure 5 shows the control cable wire connection points on the rear of the 1/4" stereo jack.

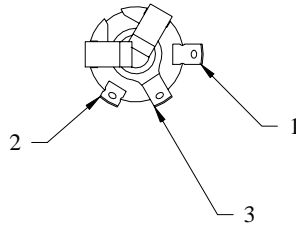

PIN 1 - BLACK WIRE  
 PIN 2 - RED WIRE  
 PIN 3 - SHIELD WIRE

**Figure 5 1/4" Stereo Jack Wiring Diagram**

A 1/4" stereo plug is attached to the scoreboard end of each control cable. The 1/4" stereo plugs are inserted into the appropriate SERIAL DATA INPUT 1/4" stereo jacks mounted on top of the scoreboard. Most customers order the control cables with the 1/4" stereo plugs attached. Some customers prefer to attach them after the cables are installed. Those customers must solder the 1/4" stereo plugs to the cables according to the figure 6. Unscrew the stereo plug cover from the plug body to expose the contact pins.

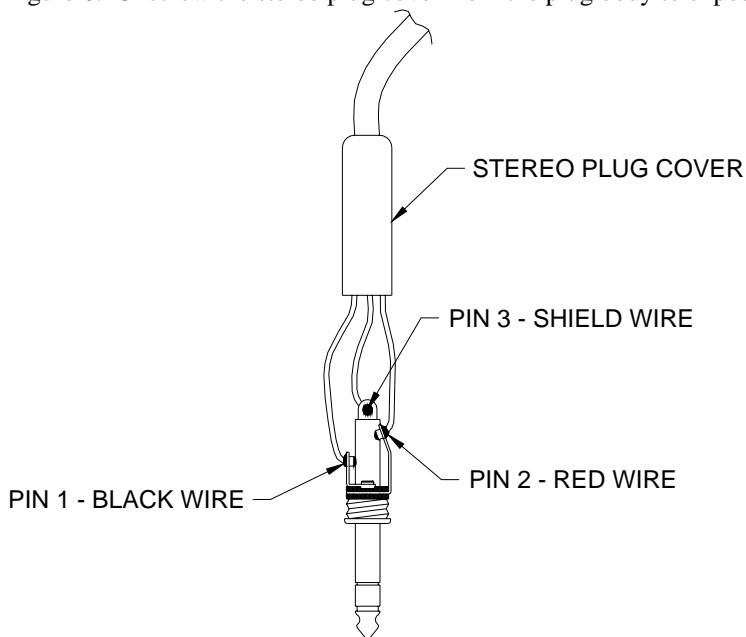

**Figure 6 1/4" Stereo Plug Wiring Diagram**

### Control Console Connections

Each 10 ft. extension cable has two molded 1/4" stereo plugs attached to it. Three cables are provided to connect the control consoles to the junction boxes. The following steps describe how to connect the control consoles:

1. Plug one end of an extension cable into the 1/4" stereo jack on the junction box connected to the control cable for the GUEST STAT PANEL section of the scoreboard or the ScoreLink 200 Transmitter for that section, if purchased.

2. Plug the other end into one of the ¼" stereo jacks mounted on the GUEST TEAM'S 2057 control console back plate.
3. Plug the GUEST TEAM'S 2057 control console power cord into a grounded NEMA 5-15R 120 VAC receptacle.
4. If a ScoreLink 200 RF MODEM SYSTEM is installed with this scoreboard, plug a wall mount DC power supply into a grounded NEMA 5-15R 120 VAC receptacle and the male plug on the end of the attached cable into the Power jack on the Transmitter for the GUEST STAT PANEL section.
5. Plug one end of another extension cable into the ¼" stereo jack on the junction box connected to the control cable for the middle section of the scoreboard or the ScoreLink 200 Transmitter for that section, if purchased.
6. Plug the other end into one of the four ¼" stereo jacks mounted on the 2550 control console back plate.
7. Plug the 2550 control console power cord into a grounded NEMA 5-15R 120 VAC receptacle.
8. If a ScoreLink 200 RF MODEM SYSTEM is installed with this scoreboard, plug a wall mount DC power supply into a grounded NEMA 5-15R 120 VAC receptacle and the male plug on the end of the attached cable into the Power jack on the Transmitter for the middle section.
9. Plug one end of the third extension cable into the ¼" stereo jack on the junction box connected to the control cable for the HOME STAT PANEL section of the scoreboard or the ScoreLink 200 Transmitter for that section, if purchased.
10. Plug the other end into one of the ¼" stereo jacks mounted on the HOME TEAM'S 2057 control console back plate.
11. Plug the HOME TEAM'S 2057 control console power cord into a grounded NEMA 5-15R 120 VAC receptacle.
12. If a ScoreLink 200 RF MODEM SYSTEM is installed with this scoreboard, plug a wall mount DC power supply into a grounded NEMA 5-15R 120 VAC receptacle and the male plug on the end of the attached cable into the Power jack on the Transmitter for the HOME STAT PANEL section.

### **Control Console Safety Warning**

This product is equipped with a 3-wire grounding type plug, a plug having a third (grounding) pin. This plug will only fit into a grounding-type power outlet. This is a safety feature. If you are unable to insert the plug into the outlet, contact a qualified electrician to replace your obsolete outlet. Do not defeat the purpose of the grounding-type plug.

### **Goal Lights Installation**

This scoreboard can control a set of goal lights. The following steps describe how to install a goal light:

1. Mount the goal light in the desired location.
2. Splice wires (not provided) to the two wire leads of the goal light.
3. Attach a polarized plug to the other end of the wires.
4. Insert the plug into the goal light receptacle on the right side of the scoreboard cabinet. The goal light receptacle is protected by a 1 amp fuse. Do not insert bulbs greater than 40 watts in the goal lights.

### **Installation of Two or More Scoreboards at the Same Site**

The following model scoreboards are compatible with the 2550 control console: 2150, 2170, 2350, 2370, 2550, 2577 (middle section), 2570, 2577 (middle section), 2650, 2655, 2350-4, 2650-4, 2655-4, 2770. The following model scoreboards are compatible with the 2057 control console: 2577 (home or guest stat panel sections) and 2577 (home or guest stat panel sections). One console can control up to 4 compatible scoreboards using control cables or an unlimited number of compatible scoreboards by installing a ScoreLink 200 Transmitter at the control console and a ScoreLink Receiver at each scoreboard. **Never splice the control cables together or connect them to the same junction box.** Each scoreboard will need to be connected to 120 VAC service.

---

## SCOREBOARD OPERATION

### SCOREBOARD STARTUP

1. Place the circuit breaker for the scoreboard in the **ON** position.
2. Plug one end of an extension cable into the ¼" stereo jack on the junction box connected to the control cable for the GUEST STAT PANEL section of the scoreboard or the ScoreLink 200 Transmitter for that section, if purchased.
3. Plug the other end into one of the ¼" stereo jacks mounted on the GUEST TEAM'S 2057 control console back plate.
4. Plug the GUEST TEAM'S 2057 control console power cord into a grounded NEMA 5-15R 120 VAC receptacle.
5. If a ScoreLink 200 RF MODEM SYSTEM is installed with this scoreboard, plug a wall mount DC power supply into a grounded NEMA 5-15R 120 VAC receptacle and the male plug on the end of the attached cable into the Power jack on the Transmitter for the GUEST STAT PANEL section.
6. Plug one end of an extension cable into the ¼" stereo jack on the junction box connected to the control cable for the middle section of the scoreboard or the ScoreLink 200 Transmitter for that section, if purchased.
7. Plug the other end into one of the four ¼" stereo jacks mounted on the 2550 control console back plate.
8. Plug the 2550 control console power cord into a grounded NEMA 5-15R 120 VAC receptacle.
9. If a ScoreLink 200 RF MODEM SYSTEM is installed with this scoreboard, plug a wall mount DC power supply into a grounded NEMA 5-15R 120 VAC receptacle and the male plug on the end of the attached cable into the Power jack on the Transmitter for the middle section.
10. Plug one end of an extension cable into the ¼" stereo jack on the junction box connected to the control cable for the HOME STAT PANEL section of the scoreboard or the ScoreLink 200 Transmitter for that section, if purchased.
11. Plug the other end into one of the ¼" stereo jacks mounted on the HOME TEAM'S 2057 control console back plate.
12. Plug the HOME TEAM'S 2057 control console power cord into a grounded NEMA 5-15R 120 VAC receptacle.
13. If a ScoreLink 200 RF MODEM SYSTEM is installed with this scoreboard, plug a wall mount DC power supply into a grounded NEMA 5-15R 120 VAC receptacle and the male plug on the end of the attached cable into the Power jack on the Transmitter for the HOME STAT PANEL section.

### GAME TIME OPERATION

This scoreboard is operated with three 37-key control consoles. The 2057 control consoles that operate the HOME and GUEST STAT PANEL sections are identical. The 2550 control console operates the middle section of the scoreboard. The three sections of the scoreboard operate independently. Figure 7 shows the keypad layout on the 2550 control console.

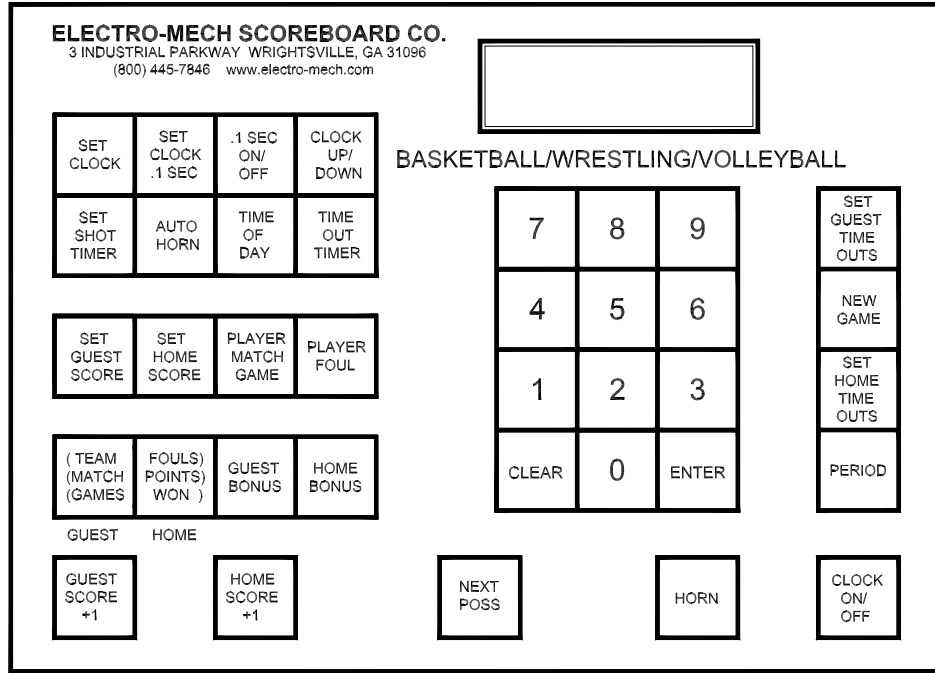

**Figure 7 2550 Keypad Layout**

Immediately after the control console power cord is plugged into a 120 VAC source, the console LCD display will read:

```
ELECTRO-MECH 2.2
SCOREBOARD MPVWV
```

After a few seconds the display will read:

```
000 D15:00 0 000
00 00 0 00
```

The scoreboard will display:

CLOCK – 15:00  
 GUEST SCORE – 0  
 HOME SCORE – 0  
 HOME TEAM FOULS – 0  
 GUEST TEAM FOULS – 0  
 HOME TIME OUTS LEFT – 5  
 GUEST TIME OUTS LEFT – 5

The control console LCD display shows the same information as the scoreboard. Note: In some functions a 0 will be blanked on the scoreboard, but not on the console LCD display. Because this console program is used for a number of models of scoreboards, some functions will appear on the console LCD display that are not present on the scoreboard. HOME and GUEST TIME OUTS LEFT are not displayed on the console LCD display. Figure 8 explains the LCD display layout.

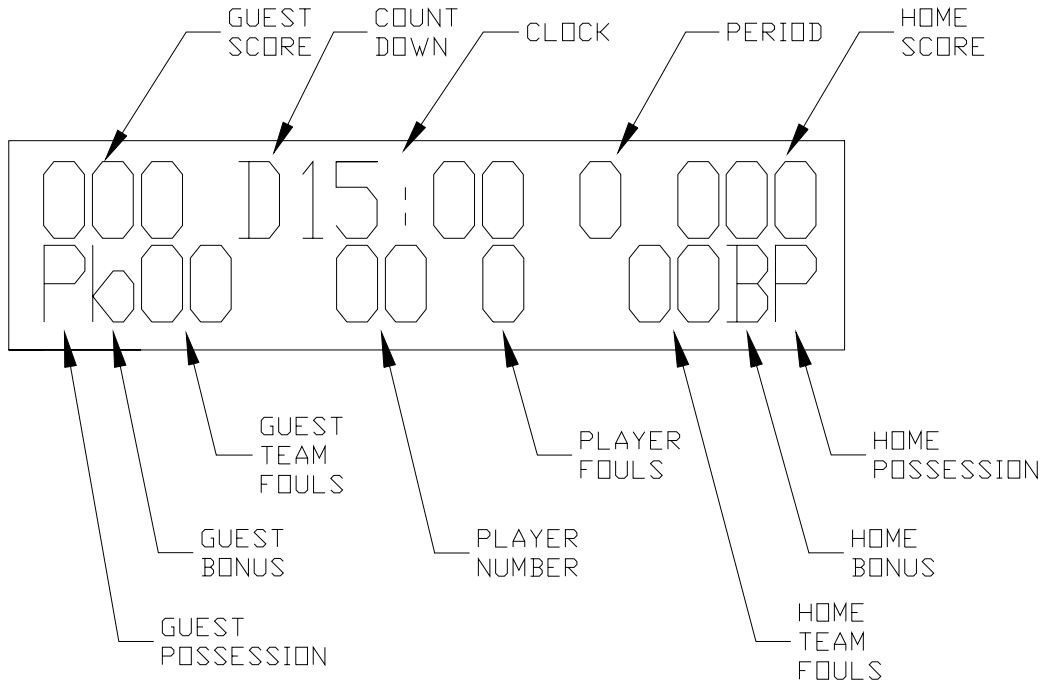

**Figure 8 Control Console LCD Display**

### 2550 Control Console Key Functions

1. **SET CLOCK** – This key sets the time displayed on the scoreboard clock. Press [SET CLOCK]. The console LCD display will read:

```
000 D15: 00 0 000
SET CLK <00: 00>
```

Press the keypad numbers for the time, [ENTER]. Example: Press [SET CLOCK], [6], [0], [0], [0], [ENTER] on the control console. 60:00 will be displayed on the clock section of the scoreboard.

2. **SET CLOCK .1 SEC** – This key is used to set the scoreboard clock to a time less than one minute when tenth of a second accuracy is required. Press [SET CLOCK .1 SEC]. The console LCD display will read:

```
000 D15: 00 0 000
SET SEC <00. 0>
```

Press the keypad numbers for the time, [ENTER]. Example: Press [SET CLOCK .1 SEC], [5], [3], [8], [ENTER] on the control console. 53.8 will be displayed on the clock section of the scoreboard.

3. **.1 SEC ON/OFF** – This key is used to enable or disable the display of tenths of seconds on the scoreboard. The use of this key has a visible effect on the scoreboard only if the game clock is less than one minute. This mode is enabled when the control console is initially turned on or reset. If it is disabled, the LCD display on the control console will still show 1/10<sup>th</sup> second timing, but the

scoreboard will not display it. To turn this function off, press [.1 SEC ON/OFF]. The console LCD display will read:

```
CLOCK  ON  <1>
.1 SEC  OFF <0>
```

Press [0], [ENTER] on the control console.

4. **CLOCK UP/DOWN** – The clock can be set up to either count up or count down. The control console is set to the clock down mode when it is initially turned on or reset. To make the clock count up, press [CLOCK UP / DOWN]. The console LCD display will read:

```
GAME    UP  <1>
CLOCK  DOWN <0>
```

Press [1], [ENTER] on the control console. The letter D in front of the game time on the console LCD will be replaced with the letter U to indicate that the clock is in the count up mode. To reset the clock to count down mode, press [CLOCK UP / DOWN], [0], [ENTER] on the control console.

5. **SET SHOT TIMER** – The console is programmed with two timers. The timers should be set prior to the start of a game. The shot timer is preset to 30 seconds. The out of bounds timer is preset to 5 seconds. To change either one of these times, press [SET SHOT TIMER]. The console LCD display will read:

```
000 D15:00 0 000
ST RESET   <30>
```

Press the keypad numbers to set shot timer, [ENTER]. The LCD display will then read:

```
00  D15:00 0 00
ST  OB RESET <05>
```

Press the keypad numbers to set the out of bounds timer, [ENTER].

6. **AUTO HORN** – This key allows the operator to control the end of period horn and the time out horn. The horn sounds for two seconds when the clock reaches 0:00 at the end of the period. The end of period horn can be disabled by pressing [AUTO HORN]. The console LCD display will read:

```
GAME PRESS<1>ON
HORN PRESS<0>OFF
```

Press [0], [ENTER] to disable the horn. The console LCD display will then read:

```
T-O  PRESS<1>ON
HORN PRESS<0>OFF
```

The time out horn is normally disabled. To enable the horn to sound at the end of the time out, press [1], [ENTER] on the control console.

7. **TIME OF DAY** – The time of day can be displayed on the clock section of the scoreboard. **THE GAME CLOCK WILL BE INOPERABLE UNTIL THE TIME OF DAY FUNCTION IS TURNED OFF.** To turn the time of day clock on, press [TIME OF DAY]. The console LCD display will read:

```
TIME OF   ON <1>
DAY CLOCK OFF<0>
```

Press [1], [ENTER] on the control console. The console LCD display will then read:

```
00  C12:00 0 00
SET CLK <12:00>
```

Press the keypad numbers for the time, [ENTER]. The letter C will be displayed on the console LCD display to the left of the time to indicate that the time of day function is active. The scoreboard will display the time of day.

8. **TIME OUT TIMER** – To set the Time Out timer, press [TIME OUT TIMER]. The console LCD display will read:

```
000 D15:00 0 000
SET T-0 <1:00>
```

Press the keypad numbers for the time, [ENTER]. After the ENTER key is pressed, the letter T is displayed to the left of the time on the LCD display and the TIME OUT TIMER immediately begins to count down to 0. The scoreboard will not display the Time Out time.

9. **SET GUEST SCORE** – To set the guest score, press [SET GUEST SCORE]. The console LCD display will read:

```
000 D15:00 0 000
GUEST SCORE<000>
```

Press the keypad numbers for the score, [ENTER]. EXAMPLE: To set the guest score to 53, press [SET GUEST SCORE], [5], [3], [ENTER].

10. **SET HOME SCORE** – To set the home score, press [SET HOME SCORE]. The console LCD display will read:

```
000 D15:00 0 000
HOME SCORE <000>
```

Press the keypad numbers for the score, [ENTER]. EXAMPLE: To set the home score to 75, press [SET HOME SCORE], [7], [5], [ENTER].

11. **GUEST BONUS** – There are two Guest Bonus indicators on the scoreboard. Guest Bonus 1 is located directly below the red Possession indicator. Guest Bonus 2 is located to the right of Guest Bonus 1. When the [GUEST BONUS] key is pressed, the Guest Bonus 1 indicator on the scoreboard

```
000 D15:00 0 000
b00 00 0 00
```

turns on and 'b' is displayed on the console LCD display as shown below.

When the [GUEST BONUS] key is pressed a second time, the Guest Bonus 1 and 2 indicators will be illuminated and 'B' is displayed on the console LCD display as shown below.

When the [GUEST BONUS] key is pressed a third time, both Guest Bonus indicators are turned off. There is no symbol in the Guest Bonus field on the console LCD display.

12. **HOME BONUS** – There are two HOME Bonus indicators on the scoreboard. HOME Bonus 1 is located directly below the red Possession indicator. HOME Bonus 2 is located to the left of HOME Bonus 1. When the [HOME BONUS] key is pressed, the HOME Bonus 1 indicator on the scoreboard turns on and 'b' is displayed on the console LCD display as shown below.

```
000 D15: 00 0 000
  00  00 0  00b
```

When the [HOME BONUS] key is pressed a second time, the HOME Bonus 1 and 2 indicators will be illuminated and 'B' is displayed on the console LCD display as shown below.

When the [HOME BONUS] key is pressed a third time, both HOME Bonus indicators are turned off. There is no symbol in the HOME Bonus field on the console LCD display.

13. **(TEAM (MATCH (GAMES GUEST** – This key is used to increment the number of fouls that the guest team has committed.

```
000 D15: 00 0 000
  00  00 0  00B
```

14. **FOULS) POINTS) WON) HOME** – This key is used to increment the number of fouls that the home team has committed.

15. **GUEST SCORE +1** – This key is used to increment the guest score by 1.

16. **HOME SCORE +1** – This key is used to increment the home score by 1.

17. **NEXT POSS** – This key toggles the possession indicators between guest and home. When the [NEXT POSS] key is pressed for the first time, the HOME Possession indicator is illuminated (a red triangle on the right side of the scoreboard) and 'P' is displayed on the console LCD display as shown below.

```
000 D15: 00 0 000
  00  00 0  00P
```

When the [NEXT POSS] key is pressed a second time, the HOME Possession indicator turns off, the GUEST Possession indicator turns on (a red triangle on the left side of the scoreboard), and 'P' is displayed on the console LCD display as shown below.

18. **HORN** – This key is used to sound the horn for ½ second.

```
000 D15: 00 0 000
P 00  00 0  00
```

19. **CLOCK ON/OFF** – This key is used to start and stop the clock.

20. **PERIOD** – This key is used to increment the period by 1.

21. **SET HOME TIME OUTS** – This key is used to display the number of time outs that the HOME team has left. To set the time outs left, press [SET HOME TIME OUTS]. The console LCD display will read:

```
000 D15: 00 0 000
HOME TO' S    <5>
```

Press the keypad numbers for the score, [ENTER]. EXAMPLE: To display that the HOME team has 3 time outs left, press [SET HOME TIME OUTS], [3], [ENTER].

22. **NEW GAME** – This key is used to reset all the scoreboard functions in this part of the scoreboard to their default settings. To reset these functions, press [NEW GAME]. The console LCD display will

```

RESET   YES<1>
SCOREBOARD NO<0>
    
```

read:

Press [1], [ENTER] on the control console. The scoreboard will reset its functions.

23. **SET GUEST TIME OUTS** – This key is used to display the number of time outs that the GUEST team has left. To set the time outs left, press [SET GUEST TIME OUTS]. The console LCD display will read:

```

000 D15:00 0 000
GUEST TO' S <5>
    
```

Press the keypad numbers for the score, [ENTER]. **EXAMPLE:** To display that the GUEST team has 1 time out left, press [SET GUEST TIME OUTS], [1], [ENTER].

24. **CLEAR** – This key clears the information being entered into the control console.

The **PLAYER MATCH GAME** and **PLAYER FOUL** keys are not used with the 2577 scoreboard.

Figure 9 shows the keypad layout on the 2057 control console.

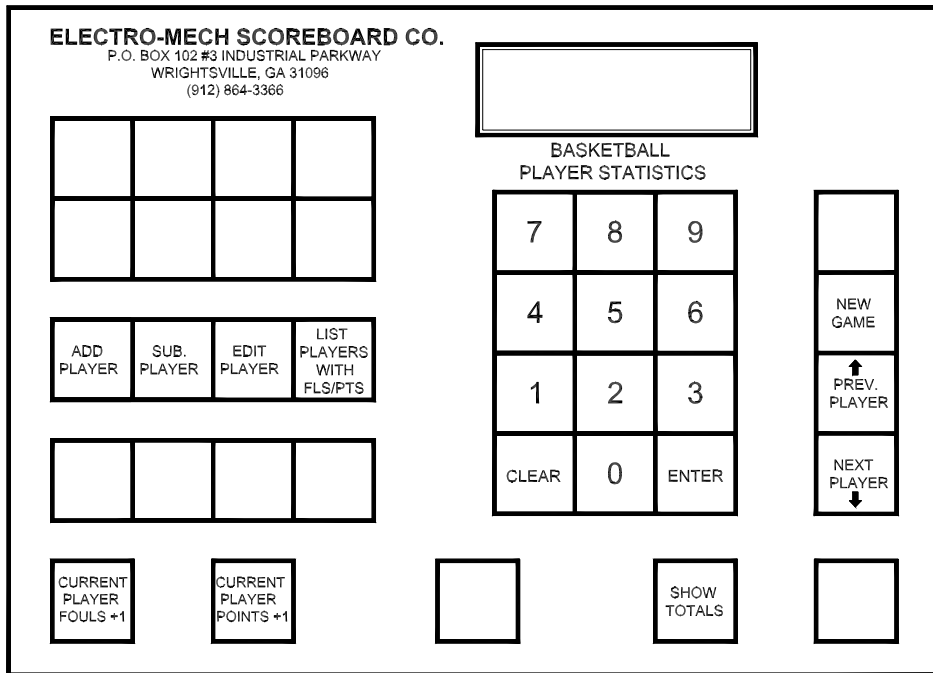

**Figure 9 2057 Keypad Layout**

Immediately after the control console power cord is plugged into a 120 VAC source, the console LCD display will read:

```

= Electro-Mech =
PROGRAM ST50
    
```

After a few seconds the display will read:

```

ADD PLAYER
ENTER NUMBER: __

```

No digits on the player stat sections of the scoreboard are illuminated at this time. The operator must enter the starting players' numbers into the control console. All other function keys are disabled until at least one player has been entered. The console will continue to prompt the operator to enter player numbers until five players have been entered, or the [ENTER] key is pressed without entering a player number, or waiting for approximately 20 seconds without pressing any keys. To enter a player's number, press the keypad numbers for the player, [ENTER]. After the five starting players have been entered, the control console LCD display will read:

```

CURRENT PLAYER
#nn FLS 0 PTS 00

```

'nn' represents the current player number.

### 2057 Control Console Key Functions

1. **CURRENT PLAYER FOULS +1** – This key is used to increment the number of fouls committed by the player currently shown on the console LCD display (CURRENT PLAYER).
2. **CURRENT PLAYER POINTS +1** – This key is used to increment the number of points scored by the player currently shown on the console LCD display (CURRENT PLAYER).
3. **NEXT PLAYER** – This key is used to select a new CURRENT PLAYER. Each time this key is pressed, the next player currently in the game is shown on the control console LCD display. This key can also be used with the LIST PLAYERS WITH FLS/PTS function to scroll down the list of players who have committed fouls and / or scored points. Note: This list may include players not currently in the game.
4. **PREV. PLAYER** – This key can also be used to select a new CURRENT PLAYER. Each time this key is pressed, the previous player in the game is shown on the control console LCD display. This key can also be used with the LIST PLAYERS WITH FL/PT function to scroll up the list of players who have committed fouls and / or scored points. Note: This list may include players not currently in the game.
5. **SUB. PLAYER** – This key is used to substitute a player currently in the game. To substitute a player, press [SUB. PLAYER]. The console LCD display will read:

```

SUBSTITUTE
PLAYER IN #__

```

Press the keypad numbers for the player entering the game, [ENTER]. The LCD display will then read:

```

#nn COMING IN
PLAYER OUT #__

```

Press the keypad numbers for the player leaving the game, [ENTER]. Note: 'nn' represents the number of the player coming into the game.

6. **EDIT PLAYER** – This key allows the operator to correct the statistics for a player. Press [EDIT PLAYER]. The console LCD display will read:

```
EDIT PLAYER
ENTER NUMBER: __
```

Press the keypad numbers for the player, [ENTER]. The console LCD display will then read:

```
PLAYER#nn FLS=0
ENTER FOULS: 0
```

Press the keypad number for the number of fouls committed, [ENTER]. The console LCD display will then read:

```
PLAYER#nn PTS=00
ENTER POINTS: 00
```

Press the keypad number for the number of points scored, [ENTER]. The console LCD display will then read:

```
REMOVE #nn?
1 <YES> 0 <NO>
```

Press [1], [ENTER] to remove a player from the scoreboard and the current player list. Press [0], [ENTER] to leave the player in the current player list and on the scoreboard. If the player is not in the current player list and on the scoreboard, pressing [1] or [0] has no effect on his status. This function can be used to remove a player number entered by mistake from the scoreboard. When removing an incorrect player number, be sure to enter 0 fouls and 0 points, so that the TOTAL FOULS, TOTAL POINTS, and the list of players with fouls and / or points are not adversely affected. This function can also be used remove a current player who has fouled out of the game, but no substitute is available. It is still possible to edit a player who has been removed. Note: 'nn' represents the player number being edited.

7. **ADD PLAYER** – If there are less than five current players, this function can be used to add players to the scoreboard. Press [ADD PLAYER]. The console LCD display will read:

```
ADD PLAYER
ENTER NUMBER: __
```

Press the keypad numbers for the player, [ENTER]. The player will be displayed on the scoreboard and added to the current player list.

8. **LIST PLAYERS WITH FLS/PTS** – This function lists the players who have committed fouls and / or scored points on the control console LCD display. The console LCD display will read:

```
#nn FLS 0 PTS 10
NEXT/PREV. /CLEAR
```

The operator can use the [NEXT PLAYER] and [PREV. PLAYER] keys to view the players on this list. Press [CLEAR] to exit this function. Note: the control console will automatically exit from this function after 5 seconds of inactivity from the operator. Note: 'nn' represents the player number.

9. **SHOW TOTALS** – To view the total number of fouls and points for the team on the control console LCD display, press [SHOW TOTALS]. The console LCD display will read:

```
TOTAL FOULS: ff
TOTAL POINTS: ppp
```

Note: The control console will automatically exit from this function after displaying the information for 5 seconds. 'ff' represents the total team fouls. 'ppp' represents the total team points.

10. **NEW GAME** – This key is used to remove all players from this section of the scoreboard and the control console memory. To perform this function, press [NEW GAME]. The console LCD display will read:

Press [1], [ENTER] on the control console. The control console LCD display will then read:

ARE YOU SURE ?
CLEAR STATS (NO)
1 (YES) 0 (NO)

Press [1], [ENTER] on the control console. If the operator presses [0] at either step, the control console and the scoreboard will retain the current game information.

11. **CLEAR** – This key clears the information being entered into the control console.

### Horn and Goal Lights Operation

The horn sounds for two seconds when the game clock reaches 0 seconds. It sounds for 0.5 seconds when the [HORN] key on the 2550 control console is pressed. The optional goal lights illuminate when the horn sounds, if installed.

### Hand Held Clock Control Unit Operation

The optional hand held clock control unit has an attached cable that is plugged into a jack on the 2550 control console back plate labeled **Clock Hand held**. It has one button that is used to toggle the clock on and off.

You should reset the scoreboard each time that it is turned on. Test out all the functions to ensure that the scoreboard is operating properly.

### SCOREBOARD SHUTDOWN

1. Place the power disconnect for the scoreboard in the **OFF** position.
2. Unplug the control consoles power cords.
3. Unplug the extension cables.
4. If a ScoreLink 300 RF MODEM SYSTEM is installed with this scoreboard, unplug the Transmitters' wall mount power supplies.
5. Store the control consoles and ScoreLink 300 Transmitters in a dry location. These units are not waterproof.

Proper scoreboard shutdown will help protect the scoreboard and control console from power surges and lightning strikes.

### SERVICING THE SCOREBOARD

While your scoreboard was designed for years of trouble-free operation, some problems may occasionally occur. Electro-Mech Scoreboard Company offers onsite service in some areas. In other areas, we can help you contact an independent service technician. In areas in which service is not available from Electro-Mech Scoreboard Company, we will make every effort to answer your questions. Our trained personnel at Electro-Mech Scoreboard Company are ready to answer your questions from Monday to Friday during the hours of 8 AM to 5 PM Eastern Standard Time. Be sure to know your scoreboard model number when calling. Scoreboard replacement parts are always available. Damaged parts can usually be repaired at a significant cost savings. Our convenient toll free number is listed at the bottom of every page in this manual.

## COMPONENT REPLACEMENT

### LED Digits And Indicators Replacement

The LEDs that form digits and indicators are soldered on circuit boards mounted behind metal masks. Do not attempt to replace individual LEDs. In case of a malfunction, the entire LED circuit board must be removed. **To avoid damage to the LED driver module, always turn off the power to the scoreboard when removing or replacing LED digits and indicators.** Figure 10 shows the components of a LED digit assembly. LED indicator assemblies are similar in construction.

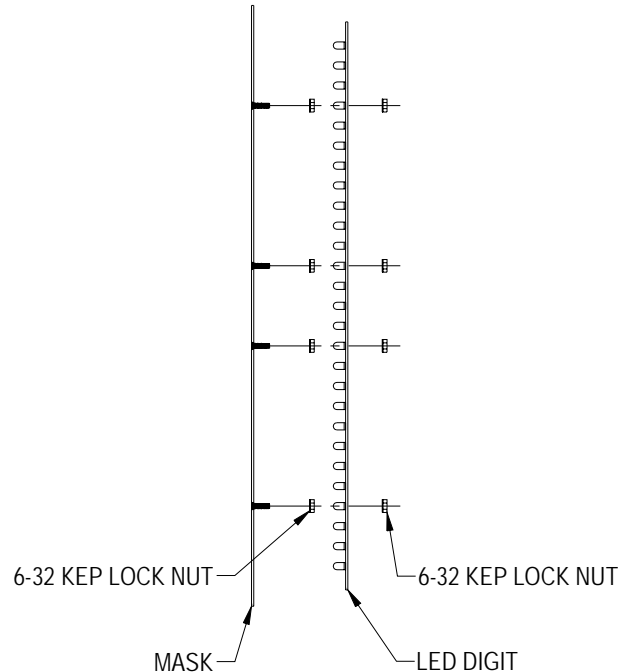

**Figure 10 LED Digit Assembly**

1. Remove the machine screws that fasten the mask to the face of the scoreboard. **Caution: Support the mask before removing the last screw. The ribbon cable that connects to the rear of the circuit board is not designed to support the weight of the assembly.**
2. Lift the assembly out of the scoreboard and disconnect the ribbon cable from the rear of the circuit board. **Caution: Do not let the cable hang outside of the scoreboard. It is easily cut by sharp metal edges. Damage to the ribbon cable may create short circuit paths that will damage the LED driver module.**
3. Place the assembly on a flat surface and remove the 6-32 kee lock nuts that hold the circuit board in place.
4. Remove the circuit board.
5. Align the mounting holes in the circuit board with the threaded studs on the mask and install the replacement digit on the mask.
6. Plug the ribbon cable onto the header on the back of the circuit board. Refer to figure 11 in order to plug the ribbon cable IDC connector onto the circuit board in the proper orientation.

LED DIGIT HEADER

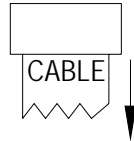
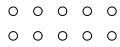

RIBBON CABLE IDC SOCKET

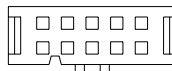

CENTER KEY

CENTER KEY ON RIBBON CABLE IDC SOCKET  
MUST POINT IN THE SAME DIRECTION AS THE  
ARROW ON THE REAR OF THE LED DIGIT.

**Figure 11 LED Digit Ribbon Cable Connection Diagram**

7. There are two circuit boards that may be used for the BONUS indicators. One circuit board has two headers and may be used for either BONUS 1 or BONUS 2. As seen in figure 12, inserting the ribbon cable IDC socket on the top header makes the circuit board operate as BONUS 1. Inserting the ribbon cable IDC socket on the bottom header makes the circuit operate as BONUS 2. The other circuit board has one header and may only be used for BONUS 1.

5-INCH BONUS  
CIRCUIT BOARD HEADERS

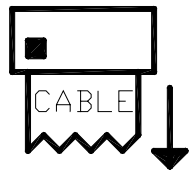

BONUS 1

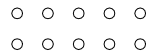

BONUS 2

RIBBON CABLE  
IDC SOCKET

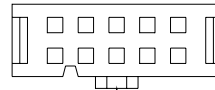

CENTER KEY

CENTER KEY ON RIBBON CABLE IDC SOCKET  
MUST POINT IN THE SAME DIRECTION AS THE  
ARROW ON THE REAR OF THE CIRCUIT BOARD.

**Figure 12 BONUS 1 and BONUS 2 Ribbon Cable Connection Diagram**

### Horn Replacement

1. Remove the machine screws that fasten the mask to the face of the scoreboard.
2. Pull the horn assembly out of the scoreboard and cut the two wires leading up to the rear of the horn assembly.
3. Splice the new horn assembly wires to the two wires inside the scoreboard.
4. Install the horn assembly and fasten it to the scoreboard face using the machine screws.

The components that control the middle section of the scoreboard are located behind the PERIOD panel. Figure 13 shows the view behind the PERIOD panel.

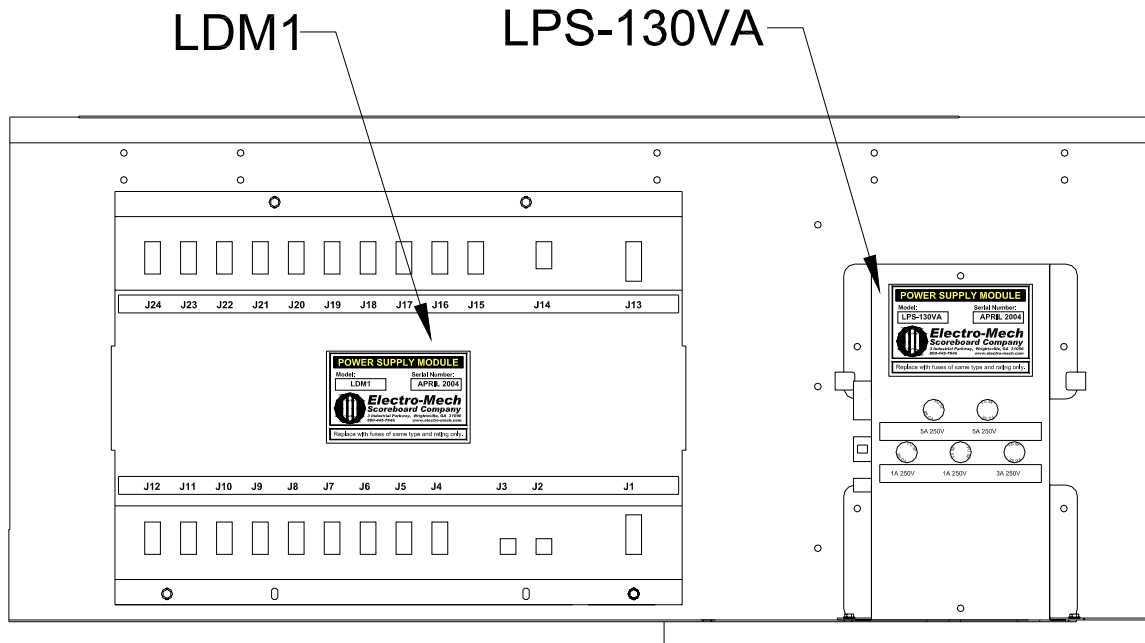

Figure 13 Middle Section Electronics

**LDM1 LED DRIVER MODULE FUNCTIONS**

<b>DRIVER MODULE JACK</b>	<b>FUNCTION #1</b>	<b>FUNCTION #2</b>	<b>FUNCTION #3</b>	<b>FUNCTION #4</b>
J1	DRIVER MODULE DC POWER INPUT #1			
J2	SERIAL DATA INPUT			
J3	SERIAL DATA OUTPUT			
J4	CLOCK SECONDS UNITS			
J5	CLOCK SECONDS TENS			
J6	CLOCK MINUTES UNITS			
J7	HOME SCORE UNITS			
J8	HOME SCORE TENS	HOME SCORE HUNDRED		
J9	GUEST SCORE UNITS			
J10	HOME FOULS UNITS	HOME FOULS TENS		
J11	GUEST FOULS UNITS			
J12	GUEST FOULS TENS			
J13	DRIVER MODULE DC POWER INPUT #2			
J14	HORN / GOAL LIGHT RELAY CONTROL			
J15	GUEST POSSESSION	GUEST BONUS 1	GUEST BONUS 2	DECIMAL / COLON
J16	QUARTER			
J17	CLOCK MINUTES TENS			
J18	NOT USED			
J19	HOME POSSESSION	HOME BONUS 1	HOME BONUS 2	
J20	GUEST SCORE TENS	GUEST SCORE HUNDRED		
J21	GUEST TIME OUTS LEFT			
J22	NOT USED			
J23	NOT USED			
J24	HOME TIME OUTS LEFT			

**LED Driver Module Replacement**

Electrical connections to the LED DRIVER MODULE are made with ribbon cable polarized IDC sockets and locking ramp crimp terminal housings that mate with jacks on the module. The module is secured inside the scoreboard with four machine screws.

1. Unplug the electrical connections from the module. Do not cut the plastic tie wraps around the ribbon cables.
2. Remove the four screws.
3. Remove the module from the scoreboard.
4. Insert the replacement module in the scoreboard.
5. Secure the module with the four screws.
6. Insert the plugs into the jacks on the module.

**To avoid damage to the module, always turn off the power to the scoreboard when removing or replacing it.**

**LPS-130VA LED POWER SUPPLY MODULE FUNCTIONS**

JACK	FUNCTION
J1	HORN CONTROL
J2	16 VDC OUTPUT TO LDM1, HORN RELAY CONTROL
J3	120 VAC INPUT

Figure 14 shows the location of the LPS-130VA Power Supply Module fuses and jack pins. The table following the figure lists the fuse ratings, functions, and part numbers.

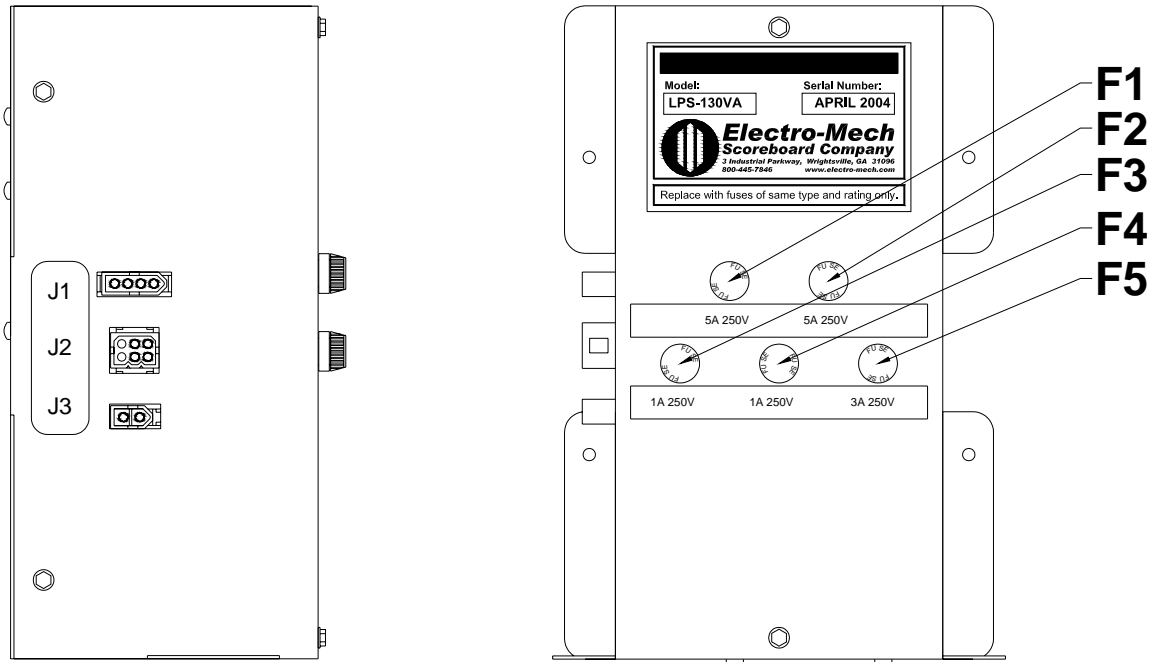

**Figure 14 LPS-130VA POWER SUPPLY MODULE**

**LPS-130VA FUSES**

FUSE	RATING	FUNCTION	BUSSMAN PART #
F1	5A 250V	DRIVER MODULE DC POWER INPUT #1	AGC-5
F2	5A 250V	DRIVER MODULE DC POWER INPUT #2	AGC-5
F3	1A 250V	GOAL LIGHT RECEPTACLE	AGC-1
F4	1A 250V	HORN	AGC-1
F5	3A 250V	MAIN AC POWER	AGC-3

Note: Other manufacturer's fuses may be substituted for the Bussmann fuses.

### LED Power Supply Module Replacement

Electrical connections to the LED POWER SUPPLY MODULE are made with keyed plugs that mate with jacks on the side of the module. The module is secured inside the scoreboard with two machine screws.

1. Disconnect the plugs from the jacks on the module.
2. Remove the two machine screws.
3. Remove the module from the scoreboard.
4. Insert the replacement module in the scoreboard.
5. Secure the module with the four screws.
6. Insert the plugs into the jacks on the side of the module.

**To avoid damage to the module, always turn off the power to the scoreboard when removing or replacing it.**

The components that control the HOME STAT PANEL section of the scoreboard are located behind the PLAYER FOULS POINTS panel on the right side of the scoreboard. The components that control the GUEST STAT PANEL section of the scoreboard are located behind the PLAYER FOULS POINTS panel on the left side of the scoreboard. The components and their functions are identical to the HOME STAT PANEL components. The LED digit assemblies for the first player number, fouls, and points must be removed before removing the panel. The following steps describe how to remove the PLAYER FOULS POINTS panel:

1. Remove the machine screws that fasten the PLAYER NUMBER mask to the panel. **Caution: Support the assembly before removing the last screw of the mask. The ribbon cables that connect to the rear of the assembly are not designed to support the weight of the assembly.**
2. Disconnect the ribbon cables from the rear of the assembly. **Caution: Do not let the cables hang outside of the scoreboard. They are easily cut by sharp metal edges. Damage to the ribbon cable may create short circuit paths that will damage the LED driver modules.**
3. Repeat Steps 1 and 2 for the FOULS and POINTS assemblies.
4. Remove the sheet metal screws that hold the panel on the scoreboard. Figure 15 shows the components behind the panel.

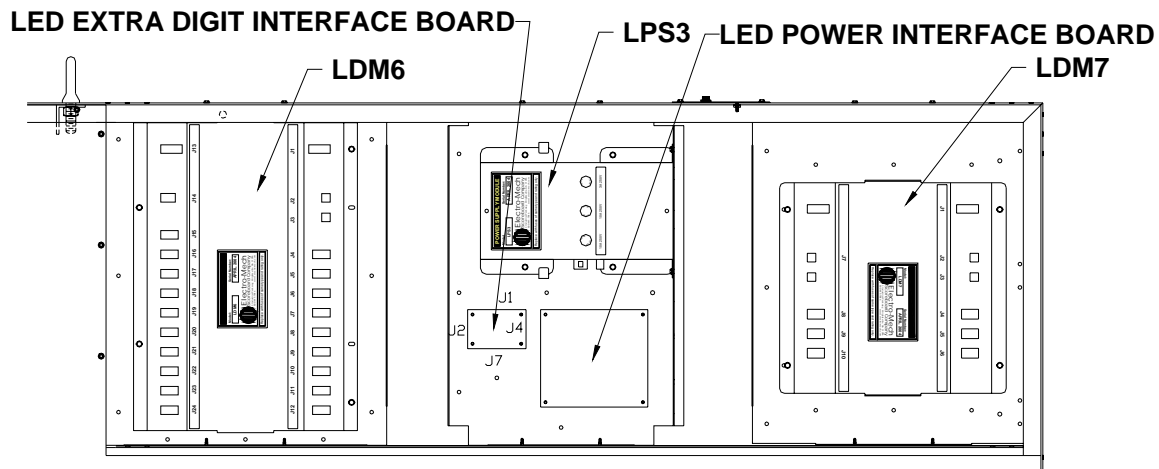

Figure 15 HOME Stat Panel Section Electronics

**LDM6 LED DRIVER MODULE FUNCTIONS**

<b>DRIVER MODULE JACK</b>	<b>FUNCTION #1</b>
J1	DRIVER MODULE DC POWER INPUT #1
J2	SERIAL DATA INPUT
J3	SERIAL DATA OUTPUT
J4	PLAYER 1 NUMBER UNITS
J5	PLAYER 1 NUMBER TENS
J6	PLAYER 1 POINTS UNITS
J7	PLAYER 3 NUMBER UNITS
J8	PLAYER 3 NUMBER TENS
J9	PLAYER 3 POINTS UNITS
J10	PLAYER 4 NUMBER UNITS
J11	PLAYER 4 NUMBER TENS
J12	PLAYER 4 POINTS UNITS
J13	DRIVER MODULE DC POWER INPUT #2
J14	LED EXTRA DIGIT INTERFACE BOARD J1
J15	LED EXTRA DIGIT INTERFACE BOARD J2
J16	PLAYER 1 FOULS
J17	PLAYER 1 POINTS TENS
J18	PLAYER 5 NUMBER UNITS
J19	PLAYER 3 FOULS
J20	PLAYER 3 POINTS TENS
J21	PLAYER 5 POINTS UNITS
J22	PLAYER 4 FOULS
J23	PLAYER 4 POINTS TENS
J24	PLAYER 5 POINTS TENS

**LDM7 LED DRIVER MODULE FUNCTIONS**

<b>DRIVER MODULE JACK</b>	<b>FUNCTION</b>
J1	DRIVER MODULE DC POWER INPUT
J2	SERIAL DATA INPUT
J3	SERIAL DATA OUTPUT
J4	PLAYER 2 NUMBER UNITS
J5	PLAYER 2 NUMBER TENS
J6	PLAYER 2 POINTS UNITS
J7	LED EXTRA DIGIT INTERFACE BOARD J3
J8	PLAYER 2 FOULS
J9	PLAYER 2 POINTS TENS
J10	PLAYER 5 NUMBER TENS

**LPS3 LED POWER SUPPLY MODULE FUNCTIONS**

<b>JACK</b>	<b>FUNCTION</b>
J1	120 VAC INPUT

J2	16 VDC OUTPUT TO LED POWER INTERFACE BOARD
----	--

Figure 16 shows the location of the LPS3 Power Supply Module fuses and jack pins. The table following the figure lists the fuse ratings, functions, and part numbers.

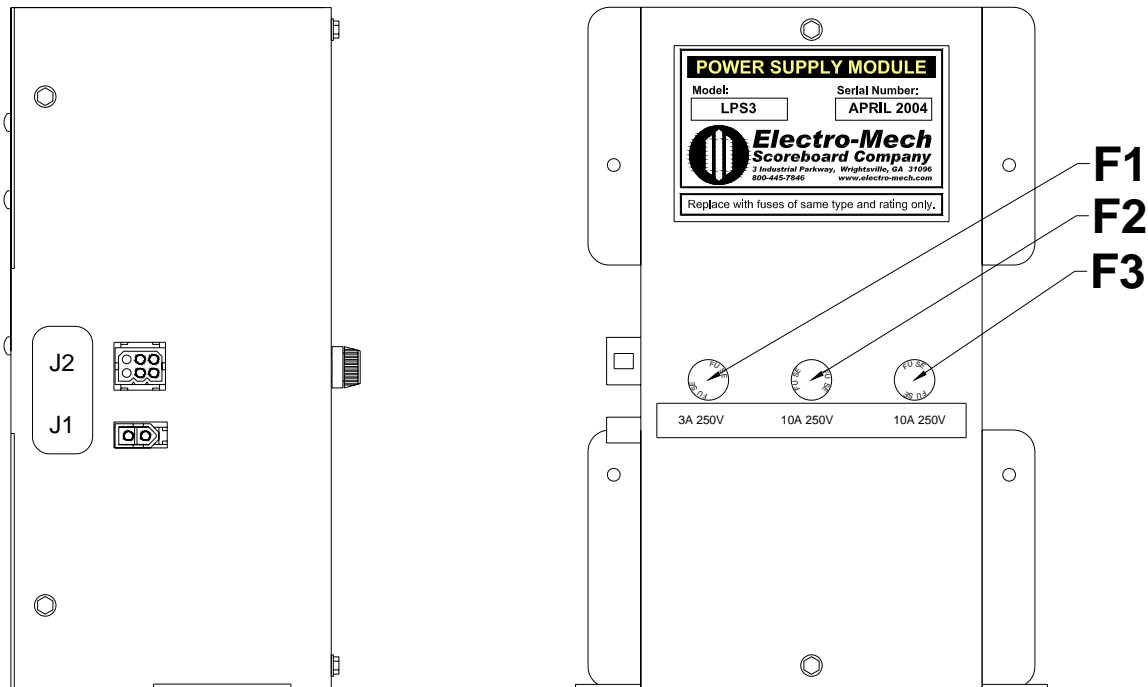

**Figure 16 LPS3 Fuse Locations**

#### LPS3 FUSES

FUSE	RATING	FUNCTION	BUSSMAN PART #
F1	3A 250V	MAIN AC POWER	AGC-3
F2	10A 250V	DC VOLTAGE OUTPUT #1	AGC-10
F3	10A 250V	DC VOLTAGE OUTPUT #2	AGC-10

Note: Other manufacturer's fuses may be substituted for the Bussmann fuses.

The LED Power Interface board distributes the output from the LPS3 power supply module to the LDM6 and LDM7 LED driver modules.

#### LED Power Interface Board Replacement

1. Unplug the wire assemblies from the jacks on the circuit board.
2. The circuit board is mounted on snap-in standoffs. Unseat the circuit board from the standoffs.
3. Press the replacement circuit board in place on the standoffs.
4. Plug the wire assemblies in the correct jacks on the circuit board. Each wire assembly is labeled to indicate the correct jack connection.

The LED EXTRA DIGIT INTERFACE BOARD takes inputs from the LDM6 and LDM7 and outputs to the position #5 fouts digit.

#### LED Extra Digit Interface Board Replacement

1. Unplug the wire and cable assemblies from the jacks on the circuit board.
2. The circuit board is mounted on snap-in standoffs. Unseat the circuit board from the standoffs.
3. Press the replacement circuit board in place on the standoffs.

4. Plug the wire and cable assemblies in the correct jacks on the circuit board. Each wire assembly is labeled to indicate the correct jack connection.

## ELECTRO-MECH SCOREBOARD CO. FIVE YEAR LIMITED WARRANTY

THE ELECTRICAL COMPONENTS OF ALL ELECTRO-MECH SCOREBOARDS ARE GUARANTEED FOR A PERIOD OF FIVE (5) YEARS FROM THE DATE OF INVOICE AGAINST DEFECTS IN WORKMANSHIP OR MATERIAL AND WILL BE REPLACED OR REPAIRED WITHOUT COST TO THE OWNER PROVIDED THE EQUIPMENT OR PARTS ARE RETURNED POSTAGE-PAID TO THE FACTORY IN WRIGHTSVILLE, GA. SHIPPING BACK TO THE OWNER WILL BE VIA UPS GROUND SERVICE EXCEPT WHEN AIR OR SPECIAL METHOD OF RETURN IS SPECIFIED BY THE OWNER, IN WHICH CASE SHIPPING WILL BE FREIGHT COLLECT.

EXCLUDED FROM THIS WARRANTY ARE FUSES.

THIS WARRANTY DOES NOT INCLUDE LABOR CHARGES INCURRED IN THE REMOVAL OF COMPONENT PARTS, SERVICE CALLS, OR DAMAGES RESULTING FROM IMPROPER INSTALLATION, IMPROPER OPERATION, OR PROBLEMS CAUSED BY ANY REPAIR, ALTERATION OR MODIFICATION OF THE SCOREBOARD NOT PERFORMED BY ELECTRO-MECH.

EQUIPMENT WHICH IS SUBJECTED TO ACCIDENT, NEGLIGENCE, ABUSE, MISUSE OR OTHER NATURAL DISASTERS, INCLUDING BUT NOT LIMITED TO FIRE, WIND, LIGHTNING, OR FLOOD, IS NOT COVERED BY THIS GUARANTEE.